



Airless Spray Technology

Owner's Manual

For professional use only

Do not use this equipment before reading this manual!

Performer 1140ix

Airless Sprayer



Model Number 800-3050

NOTE: This manual contains important warnings and instructions. Please read and retain for reference.

Table of Contents

Safety Precautions	2
Français	14
Español	16
General Description	4
Operation	4
Setup	4
Preparing to Paint.....	4
Painting	5
Electronic Pressure Control Indicators	5
Pressure Relief Procedure	6
Spraying	6
Spraying Technique	6
Practice	7
Cleanup	7
Maintenance	7
General Repair and Service Notes.....	7
Replacing the PRIME/SPRAY Valve.....	8
Replacing the Filters	8
Replacing the Motor Assembly	9
Replacing the Gears	9
Replacing the Transducer.....	10
Servicing the Fluid Section	10
Troubleshooting	12
Parts Listings	18
Main Assembly.....	18
Drive Assembly	19
Fluid Section Assembly	20
High Rider Cart	21
Filter Assembly	21
PRIME/SPRAY Assembly	22
Labels	22
Accessories	22
Electrical Schematic	23
Warranty	24

Safety Precautions

This manual contains information that must be read and understood before using the equipment. When you come to an area that has one of the following symbols, pay particular attention and make certain to heed the safeguard.



This symbol indicates a potential hazard that may cause serious injury or loss of life. Important safety information will follow.



This symbol indicates a potential hazard to you or to the equipment. Important information that tells how to prevent damage to the equipment or how to avoid causes of minor injuries will follow.

NOTE: Notes give important information which should be given special attention.



HAZARD: Injection injury - A high pressure fluid stream produced by this equipment can pierce the skin and underlying tissues, leading to serious injury and possible amputation. See a physician immediately.

DO NOT TREAT AN INJECTION INJURY AS A SIMPLE CUT! Injection can lead to amputation. See a physician immediately.

The maximum operating range of the sprayer is 3300 PSI/228BAR fluid pressure.

PREVENTION:

- NEVER aim the gun at any part of the body.
- NEVER allow any part of the body to touch the fluid stream. DO NOT allow body to touch a leak in the fluid hose.

- NEVER put hand in front of the gun. Gloves will not provide protection against an injection injury.
- ALWAYS lock gun trigger, shut pump off, and release all pressure before servicing, cleaning tip or guard, changing tip, or leaving unattended. Pressure will not be released by turning off the motor. The PRIME/SPRAY valve handle must be turned to PRIME to relieve the pressure. Refer to the PRESSURE RELIEF PRESSURE described in the pump manual.
- ALWAYS keep tip guard in place while spraying. The tip guard provides some protection but is mainly a warning device.
- ALWAYS remove the spray tip before flushing or cleaning the system.
- Paint hose can develop leaks from wear, kinking and abuse. A leak can inject material into the skin. Inspect the hose before each use.
- NEVER use a spray gun without a working trigger lock and trigger guard in place.
- All accessories must be rated at or above 3300 PSI/228 BAR. This includes spray tips, guns, extensions, and hose.

NOTE TO PHYSICIAN:

Injection into the skin is a traumatic injury. It is important to treat the injury as soon as possible. DO NOT delay treatment to research toxicity. Toxicity is a concern with some coatings injected directly into the blood stream. Consultation with a plastic surgeon or reconstructive hand surgeon may be advisable.

HAZARD: EXPLOSION AND FIRE - Solvent and paint fumes can explode or ignite. Severe injury and/or property damage can occur.

PREVENTION:

- Provide extensive exhaust and fresh air introduction to keep the air within the spray area free from accumulation of flammable vapors.
- Avoid all ignition sources such as static electricity sparks, electrical appliances, flames, pilot lights, hot objects, and sparks from connecting and disconnecting power cords or working light switches.
- Do not smoke in spray area.
- Fire extinguisher must be present and in good working order.
- Place pump at least 20 feet (6.1 m) from the spray object in a well ventilated area (add more hose if necessary). Flammable vapors are often heavier than air. Floor area must be extremely well ventilated. The pump contains arcing parts that emit sparks and can ignite vapors.
- The equipment and objects in and around the spray area must be properly grounded to prevent static sparks.
- Use only conductive or grounded high-pressure fluid hose. Gun must be grounded through hose connections.
- Power cord must be connected to a grounded circuit.
- Always flush unit into separate metal container, at low pump pressure, with spray tip removed. Hold gun firmly against side of container to ground container and prevent static sparks.
- Follow material and solvent manufacturer's warnings and instructions.
- Use extreme caution when using materials with a flashpoint below 70° F (21° C). Flashpoint is the temperature at which a fluid can produce enough vapors to ignite.
- Plastic can cause static sparks. Never hang plastic to enclose spray area. Do not use plastic drop cloths when spraying flammable materials.
- Use lowest possible pressure to flush equipment.

GAS ENGINE (WHERE APPLICABLE)

Always place sprayer outside of structure in fresh air. Keep all solvents away from engine exhaust. Never fill fuel tank with a running or hot engine. Hot surface can ignite spilled fuel. Always attach ground wire from pump to a grounded object. Refer to engine owner's manual for complete safety information.

HAZARD: EXPLOSION HAZARD DUE TO INCOMPATIBLE MATERIALS - will cause severe injury or property damage.

PREVENTION:

- Do not use materials containing bleach or chlorine.
- Do not use halogenated hydrocarbon solvents such as bleach, mildewcide, methylene chloride and 1,1,1 - trichloroethane. They are not compatible with aluminum.
- Contact your coating supplier about the compatibility of material with aluminum.

HAZARD: HAZARDOUS VAPORS - Paints, solvents, insecticides, and other materials can be harmful if inhaled or come in contact with body. Vapors can cause severe nausea, fainting, or poisoning.

PREVENTION:

- Use a respirator or mask if vapors can be inhaled. Read all instructions supplied with the mask to be sure it will provide the necessary protection.
- Wear protective eyewear.
- Wear protective clothing as required by coating manufacturer.

HAZARD: GENERAL - Can cause severe injury or property damage.

PREVENTION:

- Read all instructions and safety precautions before operating equipment.
- Follow all appropriate local, state, and national codes governing ventilation, fire prevention, and operation.
- The United States Government Safety Standards have been adopted under the Occupational Safety and Health Act (OSHA). These standards, particularly part 1910 of the General Standards and part 1926 of the Construction Standards, should be consulted.
- Use only manufacturer authorized parts. User assumes all risks and liabilities when using parts that do not meet the minimum specifications and safety devices of the pump manufacturer.
- Before each use, check all hoses for cuts, leaks, abrasion or bulging of cover. Check for damage or movement of couplings. Immediately replace hose if any of those conditions exist. Never repair a paint hose. Replace with a grounded high-pressure hose.
- All hoses, swivels, guns, and accessories must be pressure rated at or above 3300PSI/228 BAR.
- Do not spray outdoors on windy days.
- Wear clothing to keep paint off skin and hair.
- Always unplug cord from outlet before working on equipment.

Grounding Instructions

This product must be grounded. In the event of an electrical short circuit, grounding reduces the risk of electric shock by providing an escape wire for the electric current. This product is equipped with a cord having a grounding wire with an appropriate grounding plug. The plug must be plugged into an outlet that is properly installed and grounded in accordance with all local codes and ordinances.

DANGER — Improper installation of the grounding plug can result in a risk of electric shock. If repair or replacement of the cord or plug is necessary, do not connect the green grounding wire to either flat blade terminal. The wire with insulation having a green outer surface with or without yellow stripes is the grounding wire and must be connected to the grounding pin.

Check with a qualified electrician or serviceman if the grounding instructions are not completely understood, or if you are in doubt as to whether the product is properly grounded. Do not modify the plug provided. If the plug will not fit the outlet, have the proper outlet installed by a qualified electrician.

This product is for use on a nominal 120 volt circuit and has a grounding plug that looks like the plug illustrated below. A temporary adapter which looks like the adapter illustrated in the figure below may be used to connect this plug to a 2 pole receptacle as shown if a properly grounded outlet is not available.

The temporary adapter should be used only until a properly grounded outlet as shown below can be installed by a qualified electrician. The green colored rigid ear, lug, or the grounding wire extending from the adapter must be connected to a permanent ground such as a properly grounded outlet box cover. Whenever the adapter is used, it must be held in place by a metal screw.

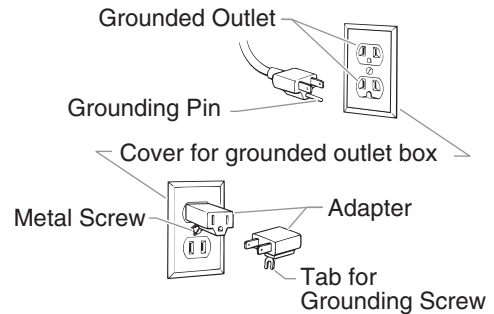

CAUTION

Use only a 3-wire extension cord that has a 3-blade grounding plug and a 3-slot receptacle that will accept the plug on the product. Make sure your extension cord is in good condition. When using an extension cord, be sure to use one heavy enough to carry the current your product will draw. An undersized cord will cause a drop in line voltage resulting in loss of power and overheating. A 12 gauge cord is recommended. If an extension cord is to be used outdoors, it must be marked with the suffix W-A after the cord type designation. For example, a designation of SJTW-A would indicate that the cord would be appropriate for outdoor use.

General Description

This airless sprayer is a precision power tool used for spraying many types of materials. Read and follow this instruction manual carefully for proper operating instructions, maintenance, and safety information.

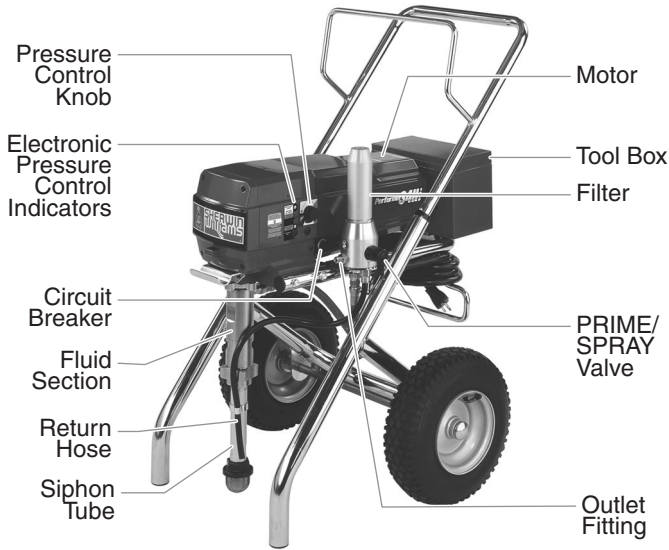

Operation

WARNING

This equipment produces a fluid stream at extremely high pressure. Read and understand the warnings in the Safety Precautions section at the front of this manual before operating this equipment.

Setup

Perform the following procedure before plugging in the power cord of an electric unit.

1. Ensure that the siphon tube/siphon set and the return hose are attached and secure.
2. Using a wrench, attach a minimum of 50' of nylon airless spray hose to the unit. Tighten securely.
3. Attach an airless spray gun to the spray hose. Using two wrenches (one on the gun and one on the hose), tighten securely.

NOTE: Do not attach the tip to the spray gun yet. Remove the tip if it is already attached.

WARNING

Make sure all airless hoses and spray guns are electrically grounded and rated for at least 3300 psi (220 bar) fluid pressure.

4. Make sure the pressure control knob is in its OFF position in the black zone.
5. Fill the wet cup with one tablespoon of piston seal lubricant (Piston Lube).

CAUTION

Never operate unit for more than ten seconds without fluid. Operating this unit without fluid will cause unnecessary wear to the packings.

6. Make sure the electrical service is 120V, 15 amp minimum.
7. Plug the power cord into a properly grounded outlet at least 25' from the spray area.

CAUTION

Always use a minimum 12 gauge, three-wire extension cord with a grounded plug. Never remove the third prong or use an adapter.

Preparing a New Sprayer

If this unit is new, it is shipped with test fluid in the fluid section to prevent corrosion during shipment and storage. This fluid must be thoroughly cleaned out of the system with mineral spirits before you begin spraying.

CAUTION

Always keep the trigger lock on the spray gun in the locked position while preparing the system.

1. Place the siphon tube into a container of mineral spirits.
2. Place the return hose into a metal waste container.
3. Move the PRIME/SPRAY valve down to the PRIME position.
4. Turn the unit on and set the pressure to minimum by turning the pressure control knob to the "Min PSI" setting in the yellow zone.

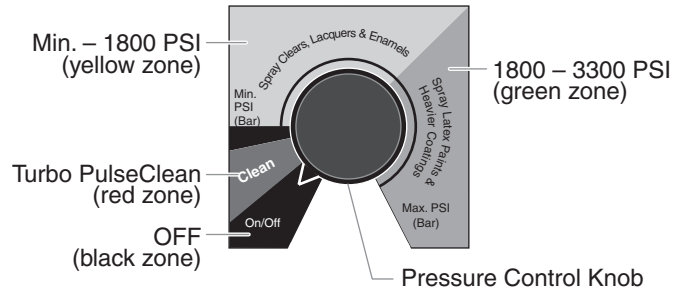

5. Allow the sprayer to run for 15–30 seconds to flush the test fluid out through the return hose and into the waste container.
6. Turn the unit off by moving the pressure control knob to the OFF position in the black zone.

Preparing to Paint

Before painting, it is important to make sure that the fluid in the system is compatible with the paint that is going to be used.

NOTE: Incompatible fluids and paint may cause the valves to become stuck closed, which would require disassembly and cleaning of the sprayer's fluid section.

CAUTION

Always keep the trigger lock on the spray gun in the locked position while preparing the system.

1. Place the siphon tube into a container of the appropriate solvent. Examples of the appropriate solvent are water for latex paint or mineral spirits for oil-based paints.
2. Place the return hose into a metal waste container.
3. Move the PRIME/SPRAY valve down to the PRIME position.
4. Turn the unit on and set the pressure to minimum by turning the pressure control knob to the "Min PSI" setting in the yellow zone.
5. Allow the sprayer to run for 15–30 seconds to flush the old solvent out through the return hose and into the metal waste container.
6. Turn the unit off by moving the pressure control knob to the OFF position in the black zone.

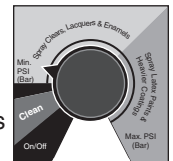

NOTE: Make sure that the spray gun does not have a tip or tip guard installed.

7. Move the PRIME/SPRAY valve up to the SPRAY position.
8. Turn the unit on and set the pressure to minimum by turning the pressure control knob to the “Min PSI” setting in the yellow zone.
9. Unlock the gun by turning the gun trigger lock to the unlocked position.

⚠ WARNING

Ground the gun by holding it against the edge of the metal container while flushing. Failure to do so may lead to a static electric discharge, which may cause a fire.



10. Trigger the gun into the metal waste container until the old solvent is gone and fresh solvent is coming out of the gun.
11. Lock the gun by turning the gun trigger lock to the locked position.
12. Set down the gun and increase the pressure by turning the pressure control knob slowly clockwise into the green zone.
13. Check the entire system for leaks. If in locked position. leaks occur, follow the “Pressure Relief Procedure” in this manual before tightening any fittings or hoses.
14. Follow the “Pressure Relief Procedure” in this manual before changing from solvent to paint.

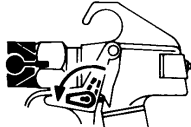

Trigger lock in locked position.

⚠ WARNING

Be sure to follow the pressure relief procedure when shutting the unit down for any purpose, including servicing or adjusting any part of the spray system, changing or cleaning spray tips, or preparing for cleanup.

Painting

1. Place the siphon tube into a container of paint.
2. Place the return hose into a metal waste container.
3. Move the PRIME/SPRAY valve down to the PRIME position.
4. Turn the unit on and set the pressure to minimum by turning the pressure control knob to the “Min PSI” setting in the yellow zone.
5. Allow the sprayer to run until paint is coming through the return hose into the metal waste container.
6. Turn the unit off by moving the pressure control knob to the OFF position in the black zone.
7. Remove the return hose from the waste container and place it in its operating position above the container of paint.
8. Move the PRIME/SPRAY valve up to the SPRAY position.
9. Turn the unit on and set the pressure to minimum by turning the pressure control knob to the “Min PSI” setting in the yellow zone.
10. Unlock the gun by turning the gun trigger lock to the unlocked position.

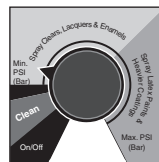

⚠ WARNING

Ground the gun by holding it against the edge of the metal container while flushing. Failure to do so may lead to a static electric discharge, which may cause a fire.



11. Trigger the gun into the metal waste container until all air and solvent is flushed from the spray hose and paint is flowing freely from the gun.

12. Lock the gun by turning the gun trigger lock to the locked position.
13. Turn the unit off by moving the pressure control knob to the OFF position in the black zone.
14. Attach tip guard and tip to the gun as instructed by the tip guard or tip manuals.

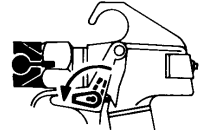

Trigger lock in locked position.

⚠ WARNING

POSSIBLE INJECTION HAZARD. Do not spray without the tip guard in place. Never trigger the gun unless the tip is in either the spray or the unclog position. Always engage the gun trigger lock before removing, replacing or cleaning tip.

15. Turn the unit on and set the pressure to minimum by turning the pressure control knob to the “Min PSI” setting in the yellow zone.
16. Increase the pressure by turning the pressure control knob slowly clockwise toward the green zone and test the spray pattern on a piece of cardboard. Adjust the pressure control knob until the spray from the gun is completely atomized.

NOTE: Turning the pressure up higher than needed to atomize the paint will cause premature tip wear and additional overspray.

Electronic Pressure Control Indicators

The following is a description of the electronic pressure control indicators.

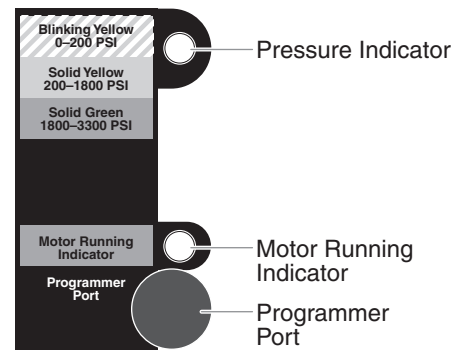

Pressure Indicator

The pressure indicator shows the current operating pressure of the sprayer. It has three different indications: blinking yellow, solid yellow, and solid green.

Blinking Yellow

When the pressure indicator is blinking yellow, the sprayer is operating between 0 and 200 PSI. A blinking yellow pressure indicator means:

- The sprayer is plugged in and turned “ON”.
- The sprayer is at priming pressure (little or no pressure).
- It is safe to move the PRIME/SPRAY valve between positions.
- It is safe to change or replace the spray tip.

NOTE: If the pressure indicator begins blinking yellow when the pressure control knob is set at a higher pressure and the PRIME/SPRAY valve is in the SPRAY position, either the spray tip is worn or the sprayer is in need of service/repair.

Solid Yellow

When the pressure indicator is solid yellow, the sprayer is operating between 200 and 1800 PSI. A solid yellow pressure indicator means:

- The sprayer is at the proper pressure setting for spraying stain, lacquer, varnish, and multi-colors.
- If the pressure indicator goes to solid yellow when the pressure is set so that it starts at solid green, it indicates one of the following:
 - a. Tip Wear Indicator — when spraying with latex or at high pressure the solid yellow appears. This means the tip is worn and needs to be replaced.
 - b. Tip Too Large — when a tip that is too large for the sprayer is put in the gun, the pressure indicator will turn from solid green to solid yellow.
 - c. Fluid Section Wear — if a solid yellow pressure indicator appears when using a new tip and the pressure is set at maximum, service may be required (worn packings, worn piston, stuck valve, etc...).

Solid Green

When the pressure indicator is solid green, the sprayer is operating between 1800 and 3300 PSI. A solid green pressure indicator means:

- The sprayer is at the proper pressure setting for spraying oil-based and latex house paints.
- The sprayer is operating at peak performance at a high pressure setting.

Motor Running Indicator

The Motor Running indicator is on when the motor is commanded to run. This indicator is used by service centers to troubleshoot motor problems.

Pressure Relief Procedure



Be sure to follow the pressure relief procedure when shutting the unit down for any purpose, including servicing or adjusting any part of the spray system, changing or cleaning spray tips, or preparing for cleanup.

1. Lock the gun by turning the gun trigger lock to the locked position.
2. Turn the pressure control knob counterclockwise to its OFF position in the black zone.
3. Unlock the gun by turning the gun trigger lock to the unlocked position.
4. Hold the metal part of the gun firmly to the side of a metal container to ground the gun and avoid a build up of static electricity.
5. Trigger the gun to remove any pressure that may still be in the hose.
6. Lock the gun by turning the gun trigger lock to the locked position.
7. Move the PRIME/SPRAY valve down to the PRIME position.



Trigger lock in locked position.



Spraying



POSSIBLE INJECTION HAZARD. Do not spray without the tip guard in place. Never trigger the gun unless the tip is in either the spray or the unclog position. Always engage the gun trigger lock before removing, replacing, or cleaning tip.

Spraying Technique

The following techniques, if followed, will assure professional painting results.

Hold the gun perpendicular to the surface and always at equal distance from the surface. Depending on the type of material, surface, or desired spray pattern, the gun should be held at a distance of 12 to 14 inches (30 to 35 cm).

Move the gun either across or up and down the surface at a steady rate. Moving the gun at a consistent speed conserves material and provides even coverage. The correct spraying speed allows a full, wet coat of paint to be applied without runs or sags.

Holding the gun closer to the surface deposits more paint on the surface and produces a narrower spray pattern. Holding the gun farther from the surface produces a thinner coat and wider spray pattern. If runs, sags, or excessive paint occur, change to a spray tip with a smaller orifice. If there is an insufficient amount of paint on the surface or you desire to spray faster, a larger orifice tip should be selected.

Maintain uniform spray stroke action. Spray alternately from left to right and right to left. Begin movement of the gun before the trigger is pulled.

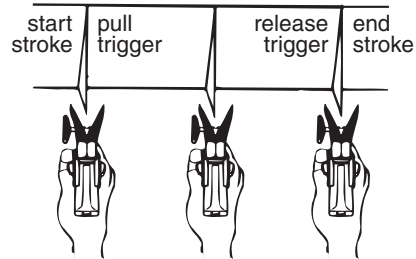

Avoid arcing or holding the gun at an angle. This will result in an uneven finish.

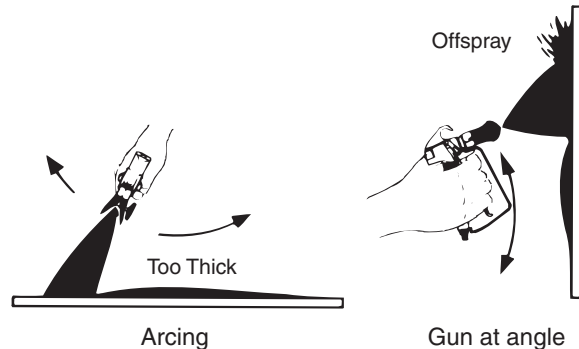

Proper lapping (overlap of spray pattern) is essential to an even finish. Lap each stroke. If you are spraying horizontally, aim at the bottom edge of the preceding stroke, so as to lap the previous pattern by 50%.

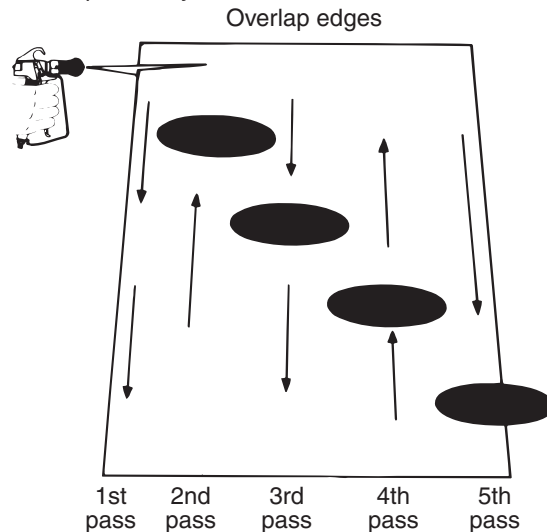

For corners and edges, split the center of the spray pattern on the corner or edge and spray vertically so that both adjoining sections receive approximately even amounts of paint.

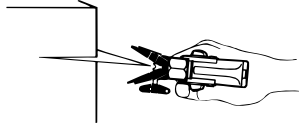

When spraying with a shield, hold it firmly against the surface. Angle the spray gun slightly away from the shield and toward the surface. This will prevent paint from being forced underneath.

Shrubs next to houses should be tied back and covered with a canvas cloth. The cloth should be removed as soon as possible. Titan gun extensions are extremely helpful in these situations. Nearby objects such as automobiles, outdoor furniture, etc. should be moved or covered whenever in the vicinity of a spray job. Be careful of any other surrounding objects that could be damaged by overspray.

Practice

1. Be sure that the paint hose is free of kinks and clear of objects with sharp cutting edges.
2. Turn the pressure control knob counterclockwise to its lowest setting.
3. Turn the PRIME/SPRAY valve up to its SPRAY position.
4. Turn the pressure control knob clockwise to its highest setting. The paint hose should stiffen as paint begins to flow through it.
5. Unlock the gun trigger lock.
6. Trigger the spray gun to bleed air out of the hose.
7. When paint reaches the spray tip, spray a test area to check the spray pattern.
8. Use the lowest pressure setting necessary to get a good spray pattern. If the pressure is set too high, the spray pattern will be too light. If the pressure is set too low, tailing will appear or the paint will spatter out in gobs rather than in a fine spray.

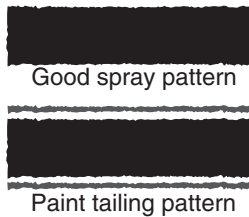

Cleanup

⚠ WARNING

Special cleanup instructions for use with flammable solvents:

- Always flush spray gun preferably outside and at least one hose length from spray pump.
- If collecting flushed solvents in a one gallon metal container, place it into an empty five gallon container, then flush solvents.
- Area must be free of flammable vapors.
- Follow all cleanup instructions.

⚠ CAUTION

The sprayer, hose, and gun should be cleaned thoroughly after daily use. Failure to do so permits material to build up, seriously affecting the performance of the unit.

⚠ WARNING

Always spray at minimum pressure with the gun nozzle tip removed when using mineral spirits or any other solvent to clean the sprayer, hose, or gun. Static electricity buildup may result in a fire or explosion in the presence of flammable vapors.

1. Follow the "Pressure Relief Procedure" found in the Operation section of this manual.
2. Remove the gun tip and tip guard and clean with a brush using the appropriate solvent.

3. Place the siphon tube into a container of the appropriate solvent. Examples of the appropriate solvent are water for latex paint or mineral spirits for oil-based paints.
4. Place the return hose into a metal waste container.
5. Move the PRIME/SPRAY valve down to its PRIME position.
6. Turn the unit on and set the pressure to Turbo PulseClean by turning the pressure control knob to its CLEAN position in the red zone.
7. Allow the solvent to circulate through the unit and flush the paint out of the return hose into the metal waste container.
8. Turn the unit off by moving the pressure control knob to the OFF position in the black zone.
9. Move the PRIME/SPRAY valve up to its SPRAY position.
10. Turn the unit on and set the pressure to Turbo PulseClean by turning the pressure control knob to its CLEAN position in the red zone.

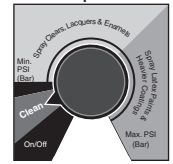

⚠ WARNING

Ground the gun by holding it against the edge of the metal container while flushing. Failure to do so may lead to a static electric discharge, which may cause a fire.



11. Trigger the gun into the metal waste container until the paint is flushed out of the hose and solvent is coming out of the gun.
12. Continue to trigger the spray gun into the waste container until the solvent coming out of the gun is clean.

NOTE: For long-term or cold weather storage, pump mineral spirits through the entire system.

For short-term storage when using latex paint, pump water mixed with Titan Liquid Shield Plus through the entire system (see the Accessories section of this manual for part number).

13. Follow the "Pressure Relief Procedure" found in the Operation section of this manual.
14. Unplug the unit and store in a clean, dry area.

⚠ CAUTION

Do not store the unit under pressure.

Maintenance

⚠ WARNING

Before proceeding, follow the Pressure Relief Procedure outlined previously in this manual. Additionally, follow all other warnings to reduce the risk of an injection injury, injury from moving parts or electric shock. Always unplug the sprayer before servicing!

General Repair and Service Notes

The following tools are needed when repairing this sprayer:

Phillips Screwdriver	3/8" Hex Wrench
Needle Nose Pliers	5/16" Hex Wrench
Adjustable Wrench	1/4" Hex Wrench
Rubber Mallet	3/16" Hex Wrench
Flat-blade Screwdriver	5/32" Hex Wrench

1. Before repairing any part of the sprayer, read the instructions carefully, including all warnings.

⚠ CAUTION

Never pull on a wire to disconnect it. Pulling on a wire could loosen the connector from the wire.

2. Test your repair before regular operation of the sprayer to be sure that the problem is corrected. If the sprayer does not operate properly, review the repair procedure to determine if everything was done correctly. Refer to the Troubleshooting Charts to help identify other possible problems.
3. Make certain that the service area is well ventilated in case solvents are used during cleaning. Always wear protective eyewear while servicing. Additional protective equipment may be required depending on the type of cleaning solvent. Always contact the supplier of solvents for recommendations.
4. If you have any further questions concerning your TITAN Airless Sprayer, call TITAN:

Customer Service (U.S.) **1-800-526-5362**
 Fax **1-800-528-4826**
 Customer Service (Canada) **1-800-565-8665**
 Fax **1-905-856-8496**
 Customer Service (International) **1-201-337-1240**
 Fax **1-201-405-7449**

Replacing the PRIME/SPRAY Valve

Perform the following procedure using PRIME/SPRAY valve replacement kit P/N 800-915.

1. Push the groove pin out of the valve handle.
2. Remove the valve handle and the cam base.
3. Using a wrench, loosen and remove the valve housing assembly.
4. Make sure the gasket is in place and thread the new valve housing assembly into the filter block. Tighten securely with a wrench.
5. Place the cam base over the valve housing assembly. Lubricate the cam base with grease and line up the cam with the filter block using the dowel pin.
6. Line up the hole on the valve stem with the hole in the valve handle.
7. Insert the groove pin into the valve handle and through the valve stem to secure the valve handle in position.

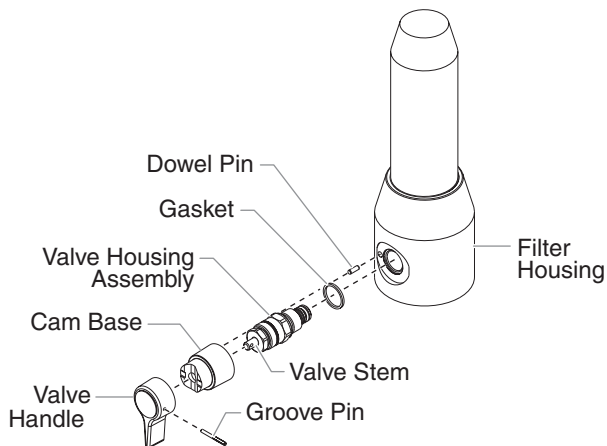

Replacing the Filters

Pump Filter

1. Loosen and remove the filter body by hand.
2. Slip the filter off of the core spring.
3. Inspect the filter. Based on inspection, clean or replace the filter.
4. Inspect the o-ring. Based on inspection, clean or replace the o-ring.
5. Slide the new or cleaned filter over the core spring with the filter spring adapter in place. Push the filter into the center of the filter housing.
6. Slide the filter body over the filter and thread it into the filter housing until secure.

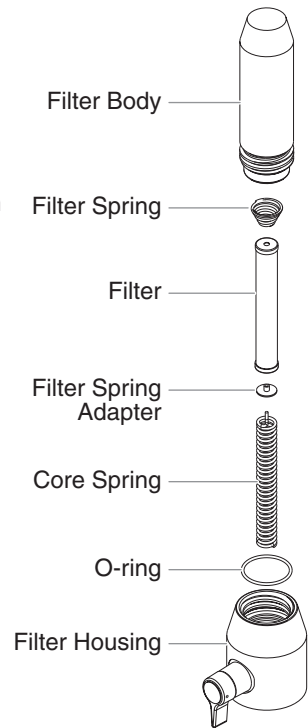

NOTE: The filter body should be hand-tightened, but make sure it is seated fully into the filter housing.

Gun Filter

1. Move the gun trigger lock to the unlocked position.
2. Loosen and remove the handle from the gun body.
3. Turning clockwise, unscrew the filter from the gun body.

NOTE: Left-handed threads require turning the filter clockwise to remove.

4. Turning counterclockwise, screw the new or cleaned filter into the gun body.
5. Make sure the handle seal is in position and thread the handle into the gun body until secure.
6. Move the gun trigger lock to the locked position.

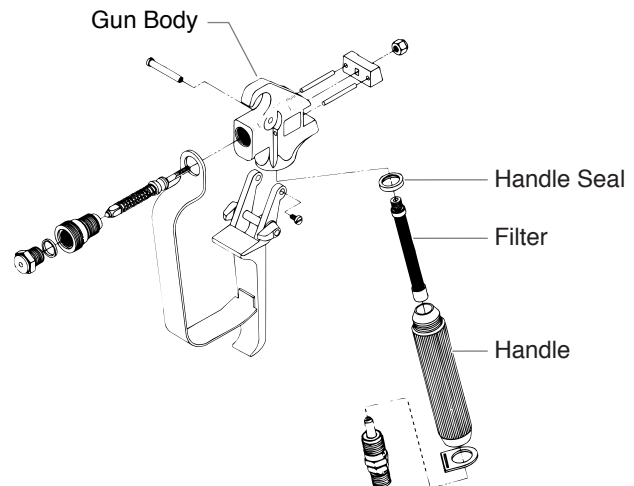

NOTE: For more detail, part number information, and assembly drawings at larger scale, please see the LX -80 Professional Airless Gun Owner's Manual (#313-012).

Replacing the Motor Assembly (with Electronic Control)

1. Unplug the unit.
2. Loosen and remove the four motor shroud screws. Remove the motor shroud.
3. Release the tie wrap on the top of the baffle assembly and slip the baffle assembly down off of the motor.
4. Loosen and remove the three electronic cover screws. Lift the electronic cover off of the electronic control assembly on the motor.
5. At the electronic control assembly:
 - a. Disconnect the white wire coming from the power cord and the white wire coming from the relay.
 - b. Disconnect the three wires coming from the potentiometer.
 - c. Disconnect the seven wires coming from the indicator lights assembly.
6. Loosen and remove the three motor mounting screws.
7. Pull the motor out of the gearbox housing.
8. With the motor removed, inspect the gears in the gearbox housing for damage or excessive wear. Replace the gears, if necessary.
9. Install the new motor into the gearbox housing. Make sure the housing gasket is positioned properly.
10. Secure the motor with the three motor mounting screws.
11. Reconnect the wires to the electronic control assembly (refer to the electrical schematic in the Parts List section of this manual).
12. Position the electronic cover over the electronic control assembly. Secure the electronic cover with the three electronic cover screws.
13. Slip the baffle assembly up and around the motor. Secure the baffle assembly with the tie wrap.
14. Slide the motor shroud over the motor. Make sure the shroud gasket is positioned properly.
15. Secure the motor shroud with the four motor shroud screws.

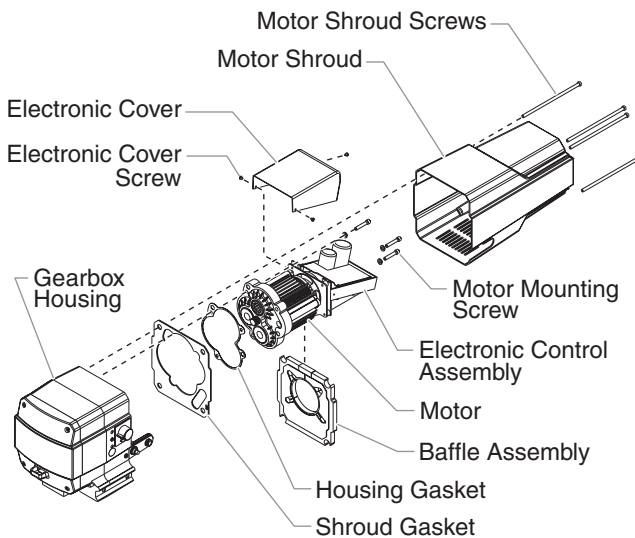

Replacing the Gears

1. Unplug the unit.
2. Loosen and remove the four motor shroud screws. Remove the motor shroud.
3. Release the tie wrap on the top of the baffle assembly and slip the baffle assembly down off of the motor.
4. Loosen and remove the three electronic cover screws. Lift the electronic cover off of the electronic control assembly on the motor.
5. At the electronic control assembly:
 - a. Disconnect the white wire coming from the power cord and the white wire coming from the relay.
 - b. Disconnect the three wires coming from the potentiometer.
 - c. Disconnect the seven wires coming from the indicator lights assembly.
6. Loosen and remove the three motor mounting screws.
7. Pull the motor out of the gearbox housing.
8. Inspect the armature gear on the end of the motor for damage or excessive wear. If this gear is completely worn out, replace the front end bell assembly.
9. Remove and inspect the 1st stage gear and 2nd stage gear assemblies for damage or excessive wear. Replace, if necessary.
10. Remove and inspect the front gear box assembly for damage or excessive wear. If damaged or worn, replace the front gear box assembly.

NOTE: Clean and refill the gear box cavity up to the rear face of each gear with Lubriplate (P/N 314-171).

11. Install the motor into the gearbox housing. Make sure the housing gasket is positioned properly.
12. Secure the motor with the three motor mounting screws.
13. Reconnect the wires to the electronic control assembly (refer to the electrical schematic in the Parts List section of this manual).
14. Position the electronic cover over the electronic control assembly. Secure the electronic cover with the three electronic cover screws.
15. Slip the baffle assembly up and around the motor. Secure the baffle assembly with the tie wrap.
16. Slide the motor shroud over the motor. Make sure the shroud gasket is positioned properly.
17. Secure the motor shroud with the four motor shroud screws.

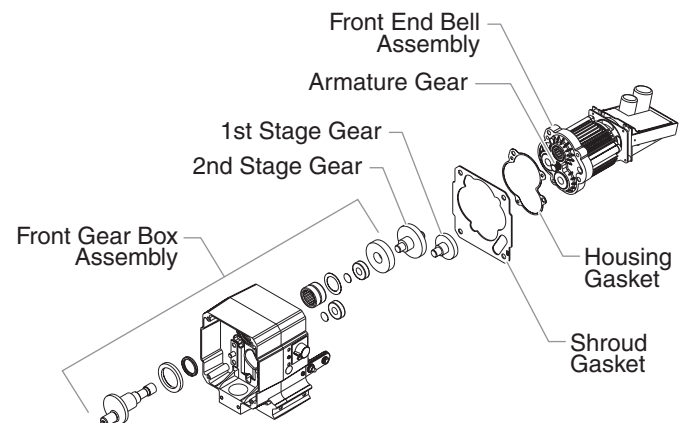

Replacing the Transducer

1. Unplug the unit.
2. Loosen and remove the four motor shroud screws. Remove the motor shroud.
3. At the electronic control assembly, disconnect the black wire coming from the transducer.
4. Pull the grommet out of the mounting plate and slide it up the shaft of the transducer until it is clear of the mounting plate.
5. Using a wrench, loosen and remove the transducer from the filter housing. Carefully thread the transducer wire out through the mounting plate.
6. Slide the grommet off of the old transducer and onto the new transducer.
7. Thread the new transducer wire through the mounting plate and up to the electronic control assembly.
8. Thread the new transducer into the filter housing and tighten securely with a wrench.

NOTE: Make sure the o-ring on the transducer is in place before threading the transducer into the filter housing.

9. Push the grommet into the mounting plate.
10. Connect the transducer wire to the electronic control assembly (refer to the electrical schematic in the Parts List section of this manual).
11. Slide the motor shroud over the motor. Make sure the shroud gasket is positioned properly.
12. Secure the motor shroud with the four motor shroud screws.

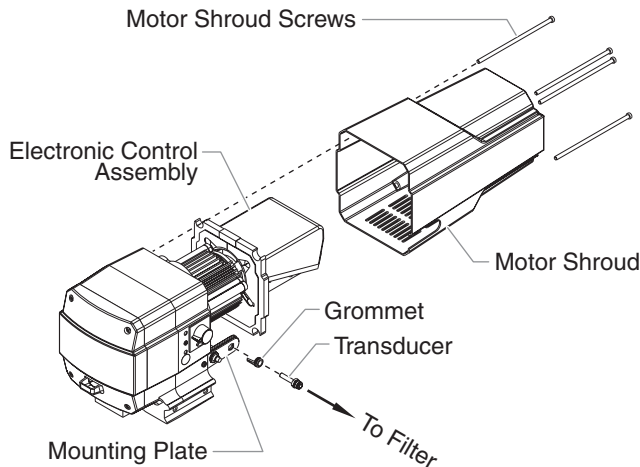

Servicing the Fluid Section

Use the following procedures to service the valves and repack the fluid section. Perform the following steps before performing any maintenance on the fluid section.

1. Loosen and remove the four front cover screws. Remove the front cover.
2. Position the crankshaft/slider assembly at the bottom, dead-center of its stroke so that the connecting pin and retaining ring are visible below the slider assembly. This is done by turning the sprayer on and off in short bursts until the connecting pin is visible below the slider housing.
3. Turn off and unplug the unit.

WARNING

Before proceeding, follow the Pressure Relief Procedure outlined previously in this manual. Additionally, follow all other warnings to reduce the risk of an injection injury, injury from moving parts or electric shock. Always unplug the sprayer before servicing!

4. Remove the return hose from the clamp on the siphon tube.
5. Unscrew the siphon tube/siphon set from the foot valve.
6. Loosen and remove the hose from the nipple on the back of the upper housing of the fluid section.

Servicing the Valves

The design of the fluid section allows access to the foot valve and seat as well as the outlet valve and seat without completely disassembling the fluid section. It is possible that the valves may not seat properly because of debris stuck in the foot valve seat or outlet valve seat. Use the following instructions to clean the valves and reverse or replace the seats.

1. Loosen and remove the foot valve housing from the lower housing.
2. Clean out any debris in the foot valve housing and examine the housing and the foot valve seat. If the seat is damaged, reverse or replace the seat.
3. Using two wrenches, hold the upper housing at the wrench flats with one wrench and loosen the lower housing with the other. Remove the lower housing.
4. Using a 3/4" wrench, loosen and remove the outlet valve retainer from the piston rod.

NOTE: Always service the outlet valve with the piston rod attached to the pump. This will prevent the piston rod from rotating during disassembly of the outlet valve.

5. Clean out any debris and examine the retainer and outlet valve seat. If the seat is damaged, reverse or replace the seat.
6. Remove, clean, and inspect the outlet valve cage and outlet valve ball. Replace if they are worn or damaged.
7. Reassemble the valves by reversing the steps above.

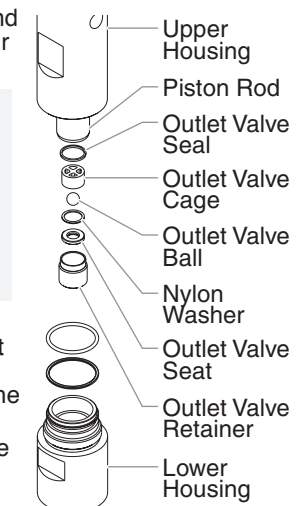
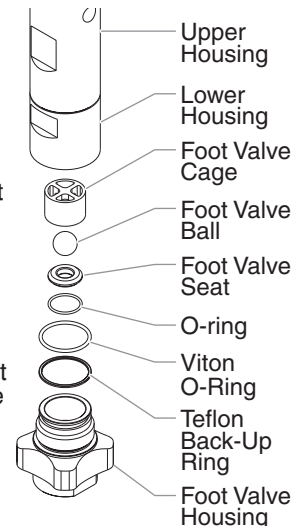

NOTE: During reassembly, make sure the Viton o-rings and the Teflon back-up rings between the upper housing and lower housing as well as between the lower housing and the foot valve housing are lubricated with grease and in position.

Repacking the Fluid Section

NOTE: The factory-installed packings are black in color. The replacement packings in the packing replacement kit are white.

1. Remove the foot valve assembly and the lower housing using the steps in the "Servicing the Valves" procedure above.

NOTE: The outlet valve does not need to be disassembled from the piston rod for this procedure.

2. Slide the retaining ring up on the slider assembly to expose the connecting pin.
3. Push the connecting pin forward through the slider assembly and piston. The connecting pin will fall into a recessed area of the gear box housing where it can be retrieved.
4. Tap the knock-off nut with a soft hammer so that it turns counterclockwise and loosens.
5. Turn the fluid section counterclockwise to remove it from the gear box housing.
6. Place the upper housing upright in a vise by clamping on the wrench flats.

NOTE: Do not over-tighten the vise. Damage to the upper housing may occur.

7. Using a wrench, remove the upper seal retainer.
8. Slide the piston rod out through the bottom of the upper housing.
9. Inspect the piston rod for wear and replace if necessary.
10. Remove the upper and lower packings from the upper housing.

NOTE: Be careful not to scratch, score, or otherwise damage the upper housing during removal of the packings.

11. Clean the upper housing. Inspect the upper housing for damage and replace if necessary.
12. Locate the new upper and lower packings and pack the areas between the packing lips with grease. Lubricate the o-rings on the exterior of the packings with grease.

13. Insert the upper packing into the top of the upper housing with the raised lip on the packing facing down.
14. Insert the spacer on top of the upper packing.
15. Thread the upper seal retainer into the upper housing and torque to 25-30 ft. lbs.

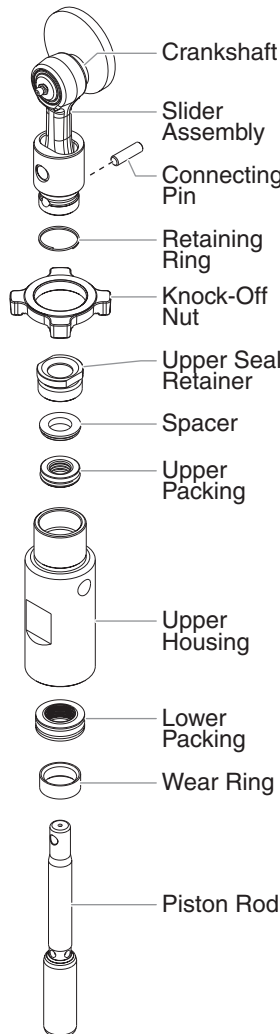

Install upper packing with raised lip facing down.



Raised Lip

16. Pre-form the lower packing using the lower packing sizing tool (included in the repacking kit).
17. Insert the lower packing partially into the bottom of the upper housing so that the side that has the o-ring closest to the face of the packing faces up.
18. Push the lower packing into position using the lower packing insertion tool (see Fluid Section Assembly parts list for lower packing insertion tool P/N).
19. Place the piston insertion tool (included in the repacking kit) over the top of the piston rod.
20. Insert the piston rod into the bottom of the upper housing, through the lower packing, through the upper packing, and out through the upper seal retainer.

Install lower packing with the side that has the o-ring closest to the face of the packing facing up.

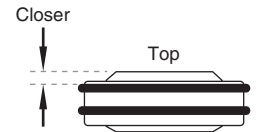

NOTE: When repacking the fluid section, make sure the raised lip on the bottom of the lower packing is fully outside the packing around the piston rod after insertion of the piston rod.

21. Remove the piston insertion tool from the top of the piston rod.
22. Turn the knock-off nut counterclockwise until it is flush against the upper housing.
23. Lubricate the threads on the upper housing with anti-seize compound. Remove the upper housing from the vise.
24. Thread the upper housing into the gear box housing, turning clockwise. When the connecting pin hole on the piston rod lines up with the hole in the slider assembly, insert the connecting pin.
25. Slide the retaining ring down over the connecting pin.
26. Continue to turn the upper housing clockwise until the knock-off nut is flush against the gear box housing.

NOTE: If the nipple on the upper housing does not face the back of the unit, turn the upper housing counterclockwise until the nipple faces the back of the unit. Do not turn the upper housing more than one full turn.

27. Once the nipple is positioned, turn the knock-off nut clockwise until it contacts the gear box housing.
28. Tap the knock-off nut with a soft hammer to tighten it against the gear box housing.
29. Making sure that the Viton o-ring and Teflon back-up ring are lubricated and in place, thread the lower housing into the upper housing. Using two wrenches, hold the upper housing at the wrench flats with one wrench and tighten the lower housing with the other.
30. Attach the high-pressure hose to the nipple on the back of the housing and tighten with a wrench. Do not kink the hose.
31. Making sure that the Viton o-ring and Teflon back-up ring are lubricated and in place, reassemble the foot valve assembly and thread it into the lower housing. Tighten securely.
32. Thread the siphon tube/siphon set into the foot valve and tighten securely. Make sure to wrap the threads on the down tube/siphon hose adapter with Teflon tape before assembly.
33. Replace the return hose into the clamp on the siphon tube.
34. Place the front cover on the gearbox housing and secure in position using the four front cover screws.
35. Turn on the sprayer by following the procedure in the "Operation" section of this manual and check for leaks.

NOTE: Repacking kit P/N 800-273 is available. For best results use all parts supplied in this kit.

Troubleshooting

Airless Sprayer

Problem

Electric motor won't run

Cause

1. Unit unplugged or circuit fuse blown
2. Pressure setting too low
3. Electric motor burned out
4. Switch defective
5. Circuit breaker on sprayer tripped

Solution

1. Check
2. Increase
3. Replace
4. Replace
5. Reset the breaker

Sprayer won't prime

1. Air in line
2. Insufficient pressure

1. Check siphon tube o-ring and/or let paint circulate in prime position
2. Increase pressure

Insufficient material flow

1. No paint
2. Siphon strainer clogged
3. Sprayer/gun filter clogged
4. Sprayer will not prime, material too heavy

1. Check supply
2. Clean
3. Clean & replace
4. Thin material

Sprayer will not maintain pressure

1. Air leak in system
2. Air leak in siphon tube
3. Inlet valve not seating
4. Worn packings
5. Dirty or worn ball valves
6. Worn valve seats
7. Worn prime valve

1. Tighten connections
2. Tighten, check for leaks
3. Service or clean
4. Replace
5. Clean or replace
6. Reverse
7. Replace

Not enough pressure

1. Pressure setting too low
2. Plugged filters
3. Spray tip too big or worn

1. Increase
2. Clean or replace
3. Change or replace

Excessive surge at spray gun

1. Wrong type of hose
2. Spray tip too big or worn
3. Excessive pressure

1. Replace with a minimum 50' grounded nylon braid high pressure hose
2. Change or replace
3. Decrease pressure and engine speed

Paint leaks into oil cup

1. Worn out packings

1. Replace

Airless Gun

Problem

Spitting gun

Cause

1. Air in system
2. Dirty gun
3. Needle assembly out of adjustment
4. Broken or chipped seat

Solution

1. Inspect connections for air leaks
2. Disassemble and clean
3. Inspect and adjust
4. Inspect and replace

Gun will not shut off

1. Worn or broken needle & seat
2. Needle assembly out of adjustment
3. Dirty gun

1. Replace
2. Adjust
3. Clean

Gun does not spray

1. No paint
2. Plugged filter or tip
3. Broken needle in gun

1. Check fluid supply
2. Clean
3. Replace

Troubleshooting

Spray Patterns

Problem

Tails

Cause

1. Inadequate fluid delivery
2. Fluid not atomizing
3. Insufficient velocity
4. Material too cohesive
5. Tip worn past sprayer capacity

Solution

1. Increase pressure
2. Change to smaller tip
3. Clean gun and pump filters
4. Reduce viscosity
5. Replace

Heavy centered pattern

1. Worn tip
2. Tip may be chipped

1. Replace
2. Replace

Distorted pattern

1. Plugged, worn or chipped tip

1. Clean or replace

Pattern expanding and contracting (Surge)

1. Leak in suction tube
2. Not enough hose
3. Tip too large or worn

1. Tighten
2. Use a minimum of 50' (15m) of 1/4" high pressure hose
3. Replace with a new or smaller tip

Patents

These products are covered by one or more of the following U.S. patents:

4,500,119 4,768,929

Consignes de sécurité

Le présent manuel comprend des renseignements devant être lus attentivement avant toute utilisation de l'appareil. Lorsque l'un des symboles suivants apparaît, il est recommandé d'être particulièrement attentif et de tenir compte des mesures de sécurité indiquées.

⚠ AVERTISSEMENT

Ce symbole indique un danger potentiel pouvant causer des blessures graves ou même mortelles. Des renseignements importants sur la sécurité sont également indiqués.

⚠ ATTENTION

Ce symbole indique un danger potentiel pouvant causer des blessures corporelles ou des dommages à l'équipement. Des renseignements importants sur la façon de prévenir tout dommage à l'équipement ou toute blessure corporelle mineure sont également indiqués.

NOTA : Les remarques donnent des renseignements importants requérant une attention particulière.

⚠ AVERTISSEMENT

DANGER: BLESSURES PAR PERFORATION - Le jet de peinture à haute pression produit par cet appareil peut perforer la peau et les tissus sous-jacents et entraîner de sévères blessures pouvant nécessiter une amputation. Consultez immédiatement un médecin.

NE PAS TRAITER UNE BLESSURE PAR PERFORATION COMME UNE SIMPLE COUPURE! Une perforation peut entraîner des risques d'amputation. Consultez immédiatement un médecin.

Pression de service maximale du fluide dans l'appareil : 3300 lb/po2 / 228BAR.

MESURES PRÉVENTIVES:

- NE JAMAIS diriger le pistolet vers une quelconque partie du corps.
- NE JAMAIS mettre une quelconque partie du corps en contact avec le jet de liquide. NE JAMAIS se mettre au contact d'un jet de liquide provenant d'une fuite du flexible d'alimentation en liquide.
- NE JAMAIS placer votre main devant le pistolet. Des gants ne vous protégeront pas contre les risques de blessures par perforation.
- TOUJOURS verrouiller la gâchette du pistolet, fermer la pompe à liquide et décompresser l'appareil lorsque vous travaillez sur celui-ci, nettoyez le protecteur de tête, remplacez la tête de pulvérisation ou vous éloignez de l'appareil. Couper le moteur ne décompresse pas l'appareil. Vous devez, pour le décompresser, placer le bouton AMORÇAGE/PULVÉRISATION en position AMORÇAGE. Reportez-vous, pour cela, à la PROCÉDURE DE DÉCOMPRESSION décrite dans de ce manuel.
- TOUJOURS s'assurer que le protecteur de tête est en place lorsque vous pulvérisez. Le protecteur de tête offre une certaine protection contre les blessures par perforation mais sa principale fonction est d'ordre préventif.
- TOUJOURS ôter la tête de pulvérisation avant de purger ou nettoyer l'appareil.
- Le flexible d'alimentation en peinture peut fuir à la suite d'une usure, de chocs ou de mauvais traitements. Une fuite peut entraîner une perforation de la peau. Inspecter le flexible avant chaque utilisation.
- NE JAMAIS utiliser un pistolet dont la gâchette n'est pas munie d'un loquet ou un cran de sécurité qui soit en état de fonctionner.
- Tous les accessoires doivent être homologués pour une pression égale ou supérieure à 3 200 lb/po2 / 228BAR. Cela s'applique, entre autres, aux têtes de pulvérisation, aux accessoires du pistolet et aux flexibles.

AVERTISSEMENT AUX MÉDECINS : Une perforation sous-cutanée constitue un traumatisme. Il est important de traiter la blessure de façon chirurgicale aussitôt que possible. NE RETARDEZ PAS ce traitement pour des recherches de toxicité. La toxicité n'est un risque que dans les cas où certains produits de revêtement pénètrent dans le flux sanguin. Il peut être nécessaire de faire appel à des soins de chirurgie plastique ou de reconstruction de la main.

DANGER: RISQUES D'EXPLOSION OU D'INCENDIE - Les vapeurs dégagées par le solvant ou la peinture sont explosives et inflammables et peuvent causer des corporels sérieux ou dommages matériels.

MESURES PRÉVENTIVES:

- Veiller à éviter toute accumulation de vapeurs inflammables en vous assurant que la zone où la pulvérisation a lieu est suffisamment ventilée.
- Veiller à éviter la présence de toute source incandescente telle qu'étincelle électrostatique, flamme nue, flamme-pilote, objet brûlant, cigarette et étincelle provenant du branchement ou du débranchement d'un cordon d'alimentation électrique ou d'un commutateur.
- Ne pas fumer dans la zone d'épandage.
- Toujours avoir un extincteur en état de fonctionner à portée de la main.
- Placer la pompe à peinture à une distance d'au moins un mètre (3 pi) (on recommande d'ailleurs une plus grande distance) de l'objet qui doit être vaporisé dans une pièce séparée bien aérée, ou à une distance d'au moins six mètres (20 pi) de celui-ci dans une zone bien aérée (utiliser d'autres tuyaux si nécessaires). Les vapeurs inflammables sont souvent plus lourdes que l'air. Le plancher doit être extrêmement bien aéré. La pompe à peinture contient des pièces pouvant créer des étincelles et enflammer les vapeurs présentes dans l'air.
- Le matériel utilisé, ainsi que les objets se trouvant à proximité de la zone de pulvérisation, doivent être convenablement reliés à la terre afin d'éviter toute étincelle ou toute décharge électrostatique.
- N'utiliser que des flexibles d'alimentation en liquide à haute pression conducteurs ou reliés à la terre dans les cas d'utilisation sans air comprimé. S'assurer que le pistolet est convenablement relié à la terre par l'intermédiaire du flexible.
- Le cordon d'alimentation doit être raccordé à un circuit mis à la terre.
- Toujours purger l'appareil dans un contenant métallique séparé, en s'assurant que la pompe soit à basse pression et que le chapeau soit retiré. Tenir le pistolet fermement contre la paroi du contenant pour mettre celui-ci à la terre et empêcher l'émission d'étincelles causées par l'électricité statique.
- Se conformer aux consignes et recommandations de sécurité du fabricant du solvant ou du produit.
- S'entourer de toutes les précautions possibles lorsqu'on utilise des produits ayant un point d'éclair inférieur à 21 °C (70 °F). Le point d'éclair d'un fluide est la température à laquelle les vapeurs émanant du fluide peuvent s'enflammer au contact d'une flamme ou d'une étincelle.
- Le plastique peut être une source d'étincelles provoquées par l'électricité statique. Ne jamais utiliser une couverture en plastique pour fermer une zone d'épandage ni utiliser des toiles de protection en plastique lors de la pulvérisation de matières inflammables.
- Lorsque vous purgez l'appareil, veillez à utiliser à la pression minimale.

MOTEUR À ESSENCE (DANS LES CAS OÙ CELA S'APPLIQUE)

Toujours placer la pompe à l'extérieur de la structure à l'air frais. Garder tous les solvants loin de l'échappement du moteur. Ne jamais remplir le réservoir à carburant lorsque le moteur est en marche ou lorsqu'il est chaud ; les surfaces chaudes risquent d'enflammer le carburant déversé accidentellement. Toujours raccorder un fil de mise à la terre entre la pompe et un objet mis à la terre, tel qu'une conduite d'eau métallique. Se reporter au guide d'utilisation du moteur pour obtenir de plus amples renseignements concernant la sécurité.

DANGER: RISQUES D'EXPLOSION PAR INCOMPATIBILITÉ DES MATÉRIAUX - Peuvent être à l'origine de corporels sérieux ou dommages matériels.

MESURES PRÉVENTIVES:

- Ne pas utiliser de matériaux contenant des agents de blanchiment ou du chlore.
- Ne pas utiliser des solvants à base d'hydrocarbure halogéné tels que l'agent anticryptogamique, le chlorure de méthylène et le trichloro-éthane-1,1,1. Ces produits ne sont pas compatibles avec l'aluminium.
- Communiquer avec votre fournisseur de revêtement pour connaître la compatibilité du matériau avec l'aluminium.

DANGER: VAPEURS NOCIVES – la peinture, les solvants, les insecticides et autres matériaux peuvent être nocifs lorsqu'ils sont inhalés ou en contact avec le corps. Les vapeurs peuvent causer une nausée importante, des évanouissements ou un empoisonnement.

MESURES PRÉVENTIVES:

- Utiliser un respirateur ou un masque chaque fois qu'il y a des risques d'inhalation de vapeurs. Lire attentivement toutes les instructions se rapportant au masque pour vérifier que celui-ci vous assure une protection suffisante contre les vapeurs toxiques.
- Porter des lunettes de protection.
- Porter des vêtements de protection, conformément aux directives du fabricant de revêtement.

DANGER: GÉNÉRALITÉS - Peut causer des dommages matériels ou corporels sérieux.

MESURES PRÉVENTIVES:

- Avant d'utiliser tout équipement, lire attentivement toutes les instructions et les consignes de sécurité.
- Toujours débrancher le moteur de l'alimentation électrique avant d'effectuer des travaux sur l'appareil.
- Se conformer à la législation locale, provinciale ou fédérale pour tout ce qui concerne la ventilation, la prévention des incendies et les conditions générales d'utilisation.
- Les normes de sécurité du Gouvernement américain sont régies par le Occupational Safety and Health Act (OSHA). Il est important de consulter ces normes, en particulier la section 1910 sur les normes générales et la section 1926 sur les des normes de la construction.
- N'utiliser que les pièces autorisées par le fabricant. L'utilisateur assume tous les risques et responsabilités lorsqu'il utilise des pièces qui ne sont pas conformes aux caractéristiques techniques minimales ainsi qu'aux dispositifs de sécurité du fabricant de la pompe.
- Vérifier, avant toute utilisation, que les flexibles ne présentent pas d'entaille ou de fuite, que le couvercle ne soit pas gonflé et que les raccords ne soient pas endommagés. Si le flexible a subi l'un des dommages précités, remplacez-le immédiatement. Ne jamais réparer un flexible d'alimentation en peinture. Le remplacer par un autre flexible mis à la terre.
- Tout flexible, raccord orientable, pistolet et accessoire utilisé avec cet appareil doit pouvoir fonctionner à une pression égale ou supérieure à 3 200 lb/po2 / 228BAR.
- Ne jamais pulvériser lorsqu'il vente.
- Porter des vêtements pour protéger la peau et les cheveux contre tout contact avec la peinture.

Instructions de mise à la terre

Cet appareil doit être mis à la terre. La mise à la terre réduit les risques d'électrocution lors d'un court-circuit en permettant au courant de s'écouler par le fil de mise à la terre. Cet appareil est muni d'un cordon électrique avec fil de mise à la terre ainsi que d'une fiche de terre. La fiche doit être branchée sur une prise installée correctement et mise à la terre conformément à la réglementation et aux codes en vigueur.

DANGER — Une prise de terre mal branchée peut être à l'origine d'électrocutions. S'il s'avère nécessaire de réparer ou de remplacer le cordon électrique ou la fiche, ne pas brancher le fil vert de mise à la terre sur l'une ou l'autre des bornes à broche plate. Le fil recouvert d'un isolant vert avec ou sans rayures jaunes est le fil de mise à la terre et doit être branché sur la broche de mise à la terre.

Si vous ne comprenez pas les instructions de mise à la terre ou si vous n'êtes pas sûr que l'appareil est correctement mis à la terre, contactez un électricien agréé. Ne pas modifier la fiche d'origine. Si la prise ne convient pas à la fiche, faites installer la prise adéquate par un électricien agréé.

Cet appareil est conçu pour une tension normale de 120 V et est muni d'une fiche de mise à la terre semblable à celle de l'illustration ci-dessous. Un adaptateur temporaire semblable à celui illustré à la figure ci-dessous, peut être utilisé pour raccorder cette fiche dans une prise bipolaire, tel qu'illustré, lorsqu'une prise de courant avec contact de mise à la terre n'est pas disponible.

L'adaptateur temporaire doit être utilisé seulement jusqu'à ce qu'une prise de courant avec contact de mise à la terre, tel qu'illustré ci-dessous, puisse être installée par un électricien qualifié. L'oreillette de fixation rigide de couleur verte ou le fil de mise à la terre raccordé à l'adaptateur doit être mis à la terre en permanence, par l'entremise d'un composant quelconque, tel qu'une boîte de sortie. Lorsque l'adaptateur est utilisé, il doit être tenu en place au moyen d'une vis métallique.

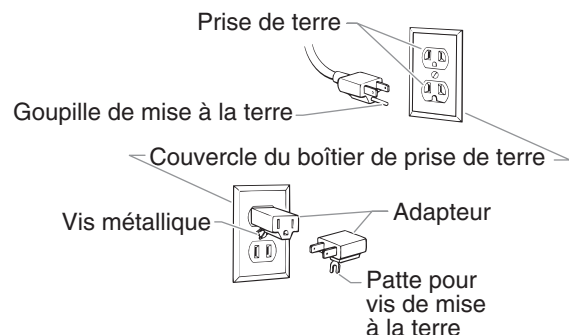

ATTENTION

Utiliser uniquement une rallonge à trois fils munie d'une fiche de terre dans une prise secteur mise à la terre correspondant au type de fiche de l'appareil. S'assurer que votre rallonge est en bon état. Lorsque vous utilisez une rallonge, assurez-vous qu'elle soit d'un calibre suffisant pour supporter l'intensité du courant requise par l'appareil. Une rallonge trop mince entraîne une chute de tension, une diminution de l'intensité et une surchauffe. Une rallonge de calibre 12 est recommandée. Si vous devez utiliser une rallonge à l'extérieur, celle-ci doit comprendre la marque W-A après la désignation indiquant le type de cordon. Par exemple, la désignation SJTW-A indique que le cordon est conçu pour être utilisé à l'extérieur.

Precauciones de seguridad

Este manual contiene información que debe leer y comprender antes de usar el equipo. Cuando se encuentre con uno de los siguientes símbolos, asegúrese de observar sus indicaciones de seguridad.

ADVERTENCIA

Este símbolo indica la existencia de un peligro potencial que puede causar lesiones graves o la muerte. Después del mismo se incluye información de seguridad importante.

PRECAUCION

Este símbolo indica la existencia de un peligro potencial para usted o el equipo. Después del mismo se incluye información importante que indica la forma de evitar daños al equipo o la forma de prevenir lesiones menores.

NOTA: los avisos contienen información importante, présteles especial atención.

ADVERTENCIA

PELIGRO: LESIÓN POR INYECCIÓN - La corriente de pintura de alta presión que produce este equipo puede perforar la piel y tejidos subyacentes, lo que conduciría a lesiones serias y una posible amputación. Consulte de inmediato a un médico.

NO TRATE LAS LESIONES POR INYECCIÓN COMO SI FUERAN SIMPLES CORTADAS! Una inyección puede conducir a una amputación. Consulte de inmediato a un médico.

El rango de operación máximo de la unidad es 3300 PSI / 228BAR de presión de fluidos.

PARA PREVENIR:

- NO dirija NUNCA la punta de la pistola hacia alguna parte del cuerpo.
- NO permita NUNCA que alguna parte del cuerpo tenga contacto con la corriente del fluido. EVITE tener contacto con corrientes de fluido que salgan de fugas que haya en la manguera.
- NO ponga NUNCA la mano enfrente de la manguera. Los guantes no ofrecen ninguna protección contra lesiones por inyección.
- Bloquee SIEMPRE el gatillo de la pistola, apague la bomba de fluido y libere toda la presión antes de dar mantenimiento, limpiar el protector de la boquilla, cambiar la boquilla o dejar desatendido el equipo. La presión no se liberará al apagar el motor. Para liberar la presión debe girarse la perilla PRIME/SPRAY (cebar/atomizar) hasta la posición PRIME. Consulte el PROCEDIMIENTO PARA LIBERAR LA PRESIÓN que se describe en este manual.
- Mantenga puesto SIEMPRE el protector de la boquilla mientras atomice. El protector de la boquilla ofrece cierta protección contra lesiones por inyección pero es principalmente un dispositivo de advertencia.
- Quite SIEMPRE la boquilla del atomizador antes de enjuagar o limpiar el sistema.
- Pueden desarrollarse fugas en la manguera de pintura por causa del desgaste, retorcimientos o el abuso. Una fuga es capaz de inyectar el material en la piel. Cada vez que use la manguera de pintura, inspecciónela antes.
- NO use nunca una pistola de atomización que no tenga un bloqueador o un protector de gatillo puesto y que funcione.
- Todos los accesorios deben tener una capacidad de 3300 lb/pulg2 / 228BAR o mayor. Esto incluye las boquillas de atomizador, pistolas, extensiones y mangueras.

NOTA PARA EL MÉDICO: La inyección dentro de la piel es una lesión traumática. Es importante que la lesión se trate quirúrgicamente tan pronto como sea posible. NO retrase el tratamiento por investigar la toxicidad. La toxicidad es motivo de preocupación con algunos revestimientos que se inyectan directamente en la corriente sanguínea. Es recomendable consultar a un cirujano plástico o reconstructor de manos.

PELIGRO: EXPLOSIÓN O INCENDIO - Los vapores de solventes y pintura pueden explotar o incendiarse, causando con esto lesiones severas y/o daños en la propiedad.

PARA PREVENIR:

- Debe proveerse un escape y aire fresco para hacer que el aire que está dentro del área de atomización se mantenga libre de acumulaciones de vapores inflamables.
- Evite todas las fuentes de ignición como son las chispas electrostáticas, llamas abiertas, flamas de piloto, objetos calientes, cigarros, y chispas que se generan al conectar y desconectar las extensiones o de apagadores de luz que estén funcionando.
- No fume en la zona de trabajo.
- Debe haber un equipo para extinguir incendios permanentemente y en buenas condiciones.
- Coloque la bomba para pintar a un mínimo de 1 m (de preferencia más) en una habitación aparte, bien ventilada, alejada del objeto que va a pintar o a por lo menos 6 m de dicho objeto, en una zona bien ventilada (utilice una manguera más larga, si es necesario). Los gases inflamables a menudo son más pesados que el aire. La zona del piso debe tener la debida ventilación. La bomba para pintar contiene piezas que forman arcos que emiten chispas y pueden encender los gases.
- El equipo que se utilice, así como los objetos que estén dentro y alrededor del área de atomización, deben conectarse a tierra de manera apropiada para prevenir las descargas eléctricas y las chispas.
- Use solamente mangueras para fluidos de alta presión, conductoras o conectadas a tierra, para aplicaciones sin aire. Asegúrese de que la pistola esté conectada a tierra de manera apropiada, mediante conexiones de manguera.
- El cable de alimentación debe enchufarse a un circuito aterrado.
- Siempre enjuague la unidad en un recipiente de metal por separado, con presión baja en la bomba y sin la boquilla. Sostenga la pistola firmemente contra el recipiente para ponerlo a tierra y evitar chispas estáticas.
- Siga las advertencias y avisos de seguridad del fabricante de los materiales y solventes.
- Tenga muchísimo cuidado al usar materiales cuyo punto de ignición sea inferior a 70° F (21° C). El punto de ignición es la temperatura a la cual pueden encenderse los vapores emanados por un fluido al exponerlos a llamas o chispas.
- El plástico puede causar chispas estáticas. Nunca cuelgue plástico en las ventanas ni en las puertas del área donde va a pintar. No utilice plástico para proteger el piso cuando pinte materiales inflamables.
- Cuando enjuague el equipo utilice la presión más baja posible.

MOTOR DE GAS (SEGÚN CORRESPONDA)

Coloque siempre la bomba fuera del edificio, al aire libre. Mantenga todo solvente alejado del escape del motor. Nunca llene el tanque de combustible si el motor está encendido o caliente. La superficie caliente puede encender el combustible derramado. Conecte siempre un conductor de tierra desde la unidad de la bomba a un objeto puesto a tierra, por ejemplo una tubería de agua metálica. Consulte el manual del motor para obtener información completa de seguridad.

PELIGRO: PELIGRO DE EXPLOSIÓN DEBIDO A MATERIALES INCOMPATIBLES - Podría causar lesiones severas o daños en la propiedad.

PARA PREVENIR:

- No utilice materiales que contengan blanqueador o cloro.
- No use solventes con hidrocarburos halogenados, tales como productos para eliminar el moho, cloruro de metileno y 1,1,1 - tricloroetano. Estos no son compatibles con el aluminio.
- Comuníquese con el proveedor del producto para obtener información de compatibilidad con materiales de aluminio.

PELIGRO: GASES PELIGROSOS - Las pinturas, solventes, insecticidas y otros materiales pueden ser perjudiciales si se inhalan o entran en contacto con el cuerpo. Los gases pueden causar náusea, desmayos o envenenamiento graves.

PARA PREVENIR:

- Use una mascarilla respiratoria o careta siempre que exista la posibilidad de que se puedan inhalar vapores. Lea todas las instrucciones que vengan con la careta para estar seguro de que se tendrá la protección necesaria contra la inhalación de vapores dañinos.
- Use gafas protectoras.
- Use ropa de protección, según lo requiera el fabricante del producto.

PELIGRO: GENERAL - Puede causar daños en la propiedad o lesiones severas.

PARA PREVENIR:

- Lea todas las instrucciones y advertencias de seguridad antes de hacer funcionar cualquier equipo.
- Desconecte siempre el motor del suministro eléctrico antes de dar servicio al equipo.
- Observe todos los códigos locales, estatales y nacionales apropiados que rigen las medidas de ventilación, prevención de incendios y operación.
- Los Estándares de Seguridad del Gobierno de los Estados Unidos se han adoptado bajo el Acta de Seguridad y Salud Ocupacionales (OSHA por sus siglas en inglés). Deben consultarse estos estándares, particularmente la parte 1910 de los Estándares Generales y la parte 1926 de los Estándares de la Construcción.
- Utilice únicamente piezas autorizadas por el fabricante. El usuario asume todos los riesgos y responsabilidades si usa piezas que no cumplen con las especificaciones mínimas y dispositivos de seguridad del fabricante de la bomba.
- Antes de usarla cada vez, revise todas las mangueras para ver que no tengan cortadas, fugas, una cubierta desgastada por abrasión o con abolladuras, así como uniones dañadas o que se hayan movido. Si existiera cualquiera de estas condiciones, reemplace la manguera inmediatamente. No repare nunca una manguera de pintura. Reemplácela con otra manguera conectada a tierra.
- Todas las mangueras, soportes giratorios, pistolas y accesorios que se usen con esta unidad deben tener una capacidad de presión de 3300 lb/pulg² / 228 BAR o mayor.
- No atomice en días con viento.
- Use ropa que evite el contacto de la pintura con la piel y el cabello.

Instrucciones para conectar a tierra

Este producto se debe conectar a tierra. En caso de que ocurra un corto circuito, la conexión a tierra reduce el riesgo de choque eléctrico al proporcionar un alambre de escape para la corriente eléctrica. Este producto está equipado con un cable que tiene un alambre de conexión a tierra con un enchufe de conexión a tierra apropiado. El enchufe se debe enchufar en una toma de corriente que se haya instalado y conectado a tierra debidamente, de acuerdo con todos los códigos y estatutos locales.

PELIGRO — Una instalación inapropiada del enchufe de conexión a tierra puede dar como resultado el que exista un riesgo de choque eléctrico. Si es necesario reparar o reemplazar el cable o el enchufe, no conecte el alambre de conexión a tierra a ninguno de los terminales de hoja planas. El alambre con aislamiento que tiene la superficie exterior de color verde con franjas amarillas o sin ellas es el alambre de conexión a tierra que debe conectarse al conector de conexión a tierra.

Verifique con un electricista o técnico de servicio calificado si las instrucciones para conectar a tierra no le han quedado completamente claras, o si duda que el producto haya quedado conectado a tierra de manera apropiada. No modifique el enchufe que se proporciona. Si el enchufe no entra en la toma de corriente, pídale a un electricista calificado que instale la toma apropiada.

Este producto está diseñado para usarse en un circuito de 120 voltios nominales y el enchufe de conexión a tierra que tiene se parece al enchufe que se ilustra a continuación. Si no dispone de una toma de corriente con conexión a tierra, puede usar un adaptador temporal que se asemeja al adaptador ilustrado en la figura a continuación, para conectar este enchufe en un receptáculo de 2 polos como se muestra.

El adaptador temporal solamente se debe utilizar hasta que un electricista calificado instale debidamente una toma de corriente con conexión a tierra. La patilla verde o alambre de conexión a tierra que se extiende desde el adaptador se debe conectar a tierra permanente, tal como la tapa de una caja de distribución conectada a tierra. Cuando use el adaptador, debe mantenerlo en su lugar con un tornillo metálico.

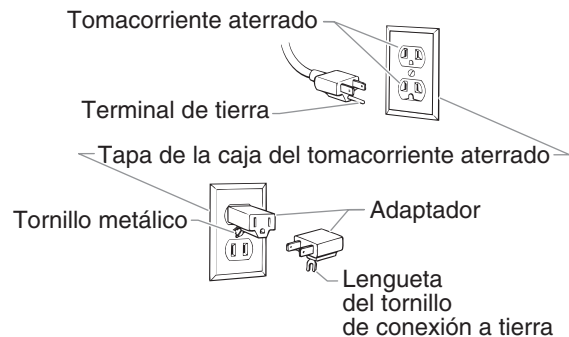

PRECAUCION

Use solamente extensiones trifilares que tengan un enchufe de conexión a tierra de 3 hojas y un receptáculo de triple ranura que acepte el enchufe del producto. Asegúrese de que su extensión esté en buenas condiciones. Cuando use una extensión, asegúrese de usar una que sea lo suficientemente resistente como para soportar la corriente que descargue su producto. Un cable de un tamaño menor causará una caída de voltage en la línea que dará como resultado una pérdida de energía y un sobrecalentamiento. Se recomienda usar un cable de calibre 12. Si se utiliza un cable de extensión en el exterior, tiene que estar marcado con el sufijo W-A después de la designación del tipo de cable. Por ejemplo, SJTW-A para indicar que el cable es apropiado para uso en exteriores.

Parts List

Main Assembly

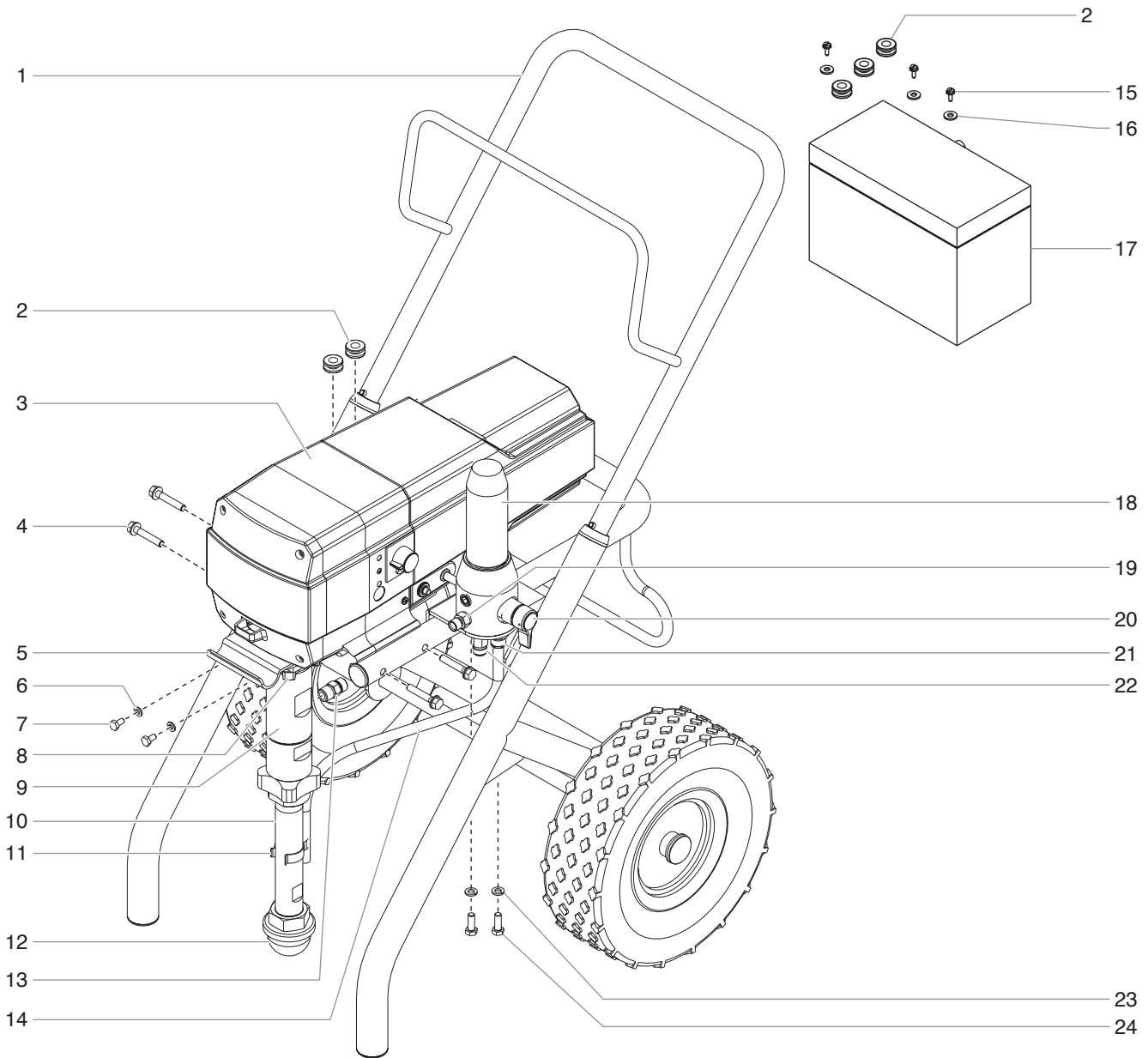

Item	Part #	Description	Quantity	Item	Part #	Description	Quantity
1	800-600	Cart assembly.....	1	14	800-904	Return hose	1
2	800-036	Grommet.....	5	15	800-129	Screw.....	3
3	-----	Drive assembly	1	16	770-601	Washer.....	3
4	761-178	Screw.....	4	17	800-047	Tool box	1
5	800-324	Pail hook.....	1	18	800-900	Filter assembly.....	1
6	763-551	Lock washer.....	2	19	812-003	Outlet fitting.....	1
7	858-625	Screw.....	2	20	800-915	PRIME/SPRAY valve assembly.....	1
8	800-328	Knock-off nut.....	1	21	800-269	Fitting.....	1
9	800-300	Fluid section assembly	1	22	800-267	Fitting.....	1
10	451-241	Siphon tube.....	1	23	860-002	Lock washer.....	2
11	730-334	Hose clamp.....	1	24	860-535	Screw.....	2
12	710-046	Inlet screen	1	25	800-266	Hose (not shown)	1
13	800-268	Fitting.....	1				

Drive Assembly

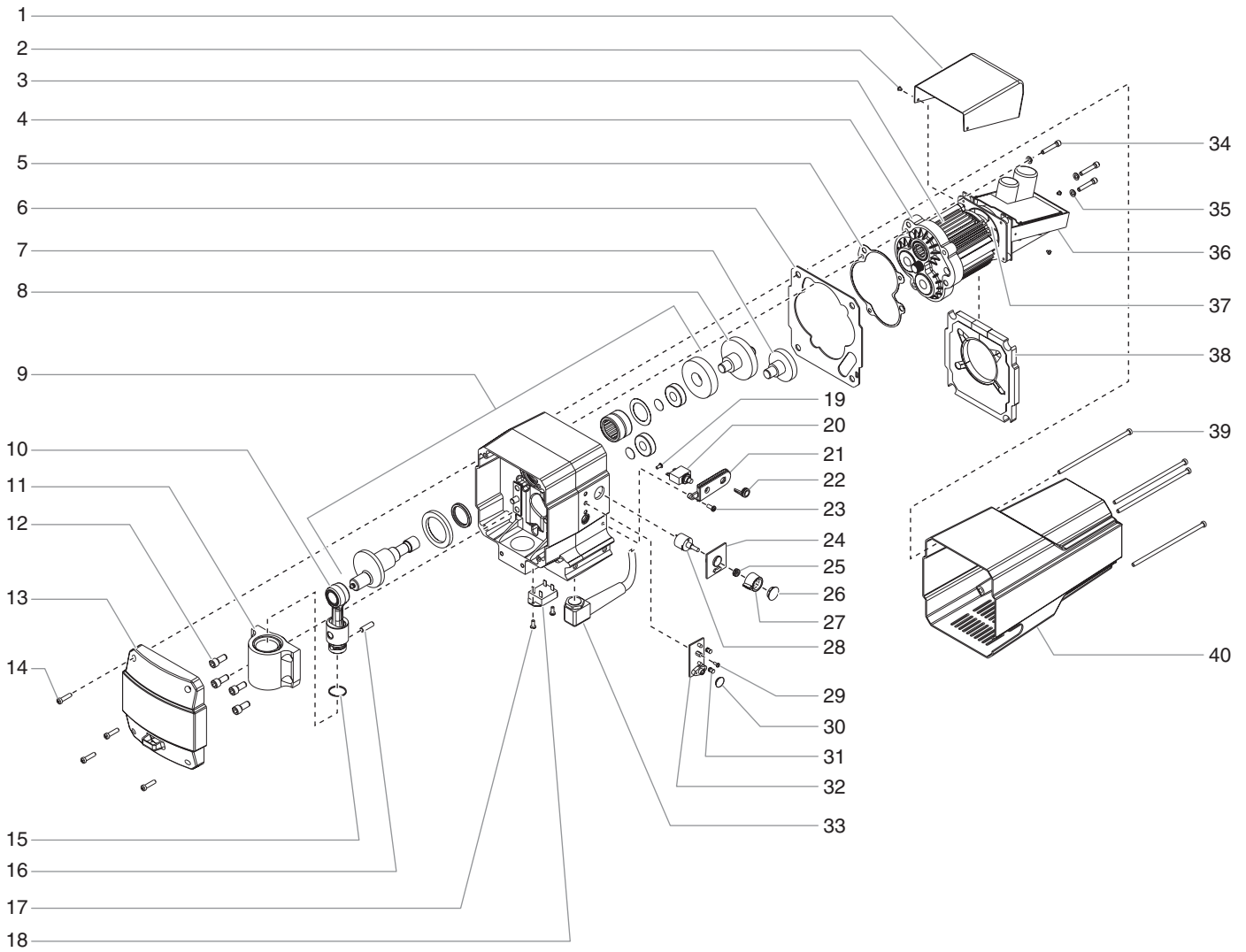

Item	Part #	Description	Quantity	Item	Part #	Description	Quantity
1	800-078	Electronic cover	1	22	800-077	Grommet.....	1
2	800-205	Screw.....	3	23	800-076	Screw.....	1
3	800-263	Motor assembly, 1.3 HP	1	24	800-274	Potentiometer mounting plate.....	1
4	800-256	Front end bell assembly	1	25	700-176	Nut	1
5	800-525	Housing gasket.....	1	26	700-175	Cap	1
6	800-541	Shroud gasket.....	1	27	700-159	Pressure control knob.....	1
7	800-261	1st stage gear assembly.....	1	28	800-277	Potentiometer	1
8	800-262	2nd stage gear assembly	1	29	800-203	Screw.....	1
9	800-260	Front gearbox assembly	1	30	704-281	Port plug	1
10	800-510	Slider assembly	1	31	800-043	LED cover	2
11	800-253	Slider housing.....	1	32	800-278	Indicator lights assembly	1
12	700-283	Screw.....	4	33	800-086	Power cord w/strain relief	1
13	800-275	Front cover with label	1	34	700-287	Screw.....	3
14	800-284	Screw.....	4	35	763-551	Lock washer.....	3
15	800-382	Retaining ring.....	1	36	800-292	Electronic control assembly.....	1
16	800-753	Connecting pin.....	1	37	800-294	Fan assembly	1
17	800-202	Screw.....	2	38	800-435	Baffle assembly	1
18	800-276	Relay.....	1	39	800-283	Screw.....	4
19	704-229	Screw.....	1	40	800-282	Motor shroud w/labels	1
20	765-327	Circuit breaker	1	41	800-366	Wire cover, 7" (not shown)	1
21	800-075	Mounting plate	1	42	800-368	Wire assembly (not shown)	1

NOTE: All electrical work should be performed by a Titan authorized service center.

Fluid Section Assembly (P/N 800-300)

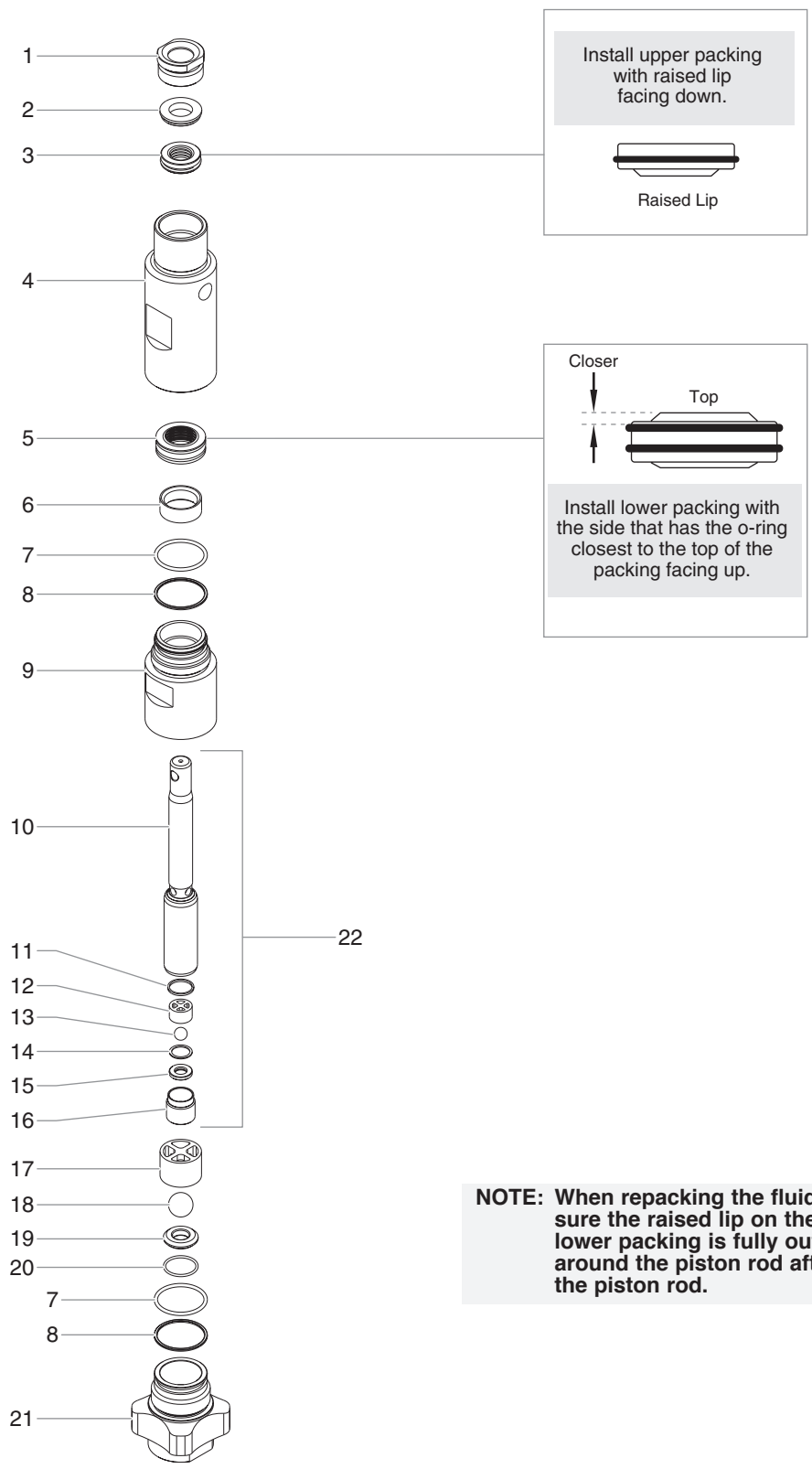

NOTE: When repacking the fluid section, make sure the raised lip on the bottom of the lower packing is fully outside the packing around the piston rod after insertion of the piston rod.

Item	Part #	Description	Quantity
1	800-325	Upper seal retainer	1
2	800-327	Spacer	1
3	800-248	Upper packing assembly	1
4	800-351	Upper housing	1
5	800-250	Lower packing assembly	1
6	800-354	Wear ring	1
7	800-332	O-ring, Viton.....	2
8	800-333	Back-up ring, Teflon.....	2
9	800-352	Lower housing	1
10	800-246	Piston rod.....	1
11	800-348	Outlet valve seal.....	1
12	800-244	Outlet valve cage.....	1
13	800-247	Outlet valve ball.....	1

Item	Part #	Description	Quantity
14	800-245	Washer, nylon	1
15	800-243	Outlet valve seat.....	1
16	800-336	Outlet valve retainer	1
17	800-322	Foot valve cage	1
18	800-242	Foot valve ball	1
19	800-241	Foot valve seat	1
20	762-058	O-ring.....	1
21	800-305	Foot valve housing	1
22	800-365	Piston assembly (includes items 10-16)....	1
	800-359	Lower packing insertion tool	
	800-273	Repacking kit (includes items 2, 3, 5-8, 11, 13, 14, 18, 20, and tool)	

High Rider Cart (P/N 800-600)

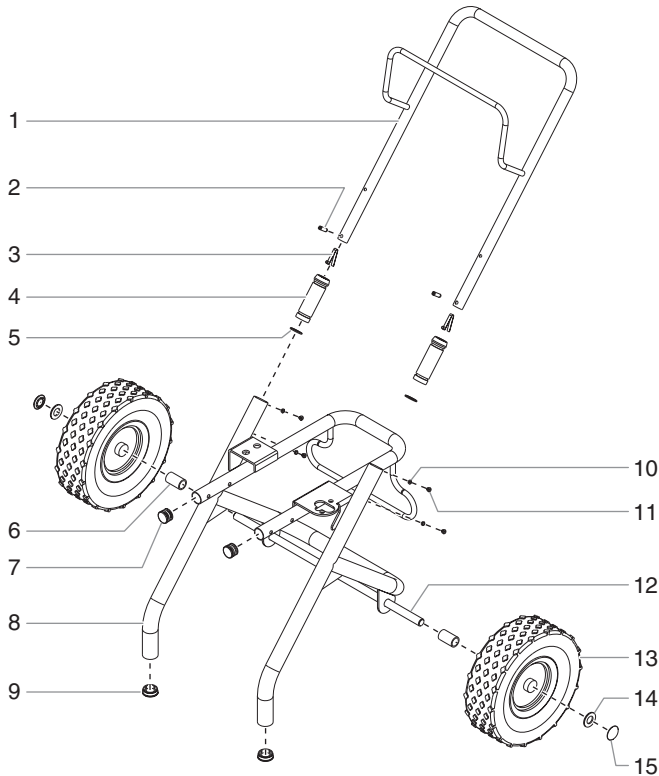

Item	Part #	Description	Quantity
1	800-280	Handle (includes items 2-5, 10, and 11)	1
2	590-508	Roll pin.....	2
3	590-507	Snap button	2
4	590-504	Sleeve.....	2
5	590-506	Washer.....	2
6	800-011	Spacer	2
7	710-199	Plug.....	2
8	800-279	Cart (includes items 7 and 9)	1
9	335-018	Plug.....	2
10	856-002	Washer.....	4
11	856-921	Screw	4
12	800-007	Axle	1
13	670-109	Wheel.....	2
14	870-004	Washer.....	2
15	800-019	Cap	2

Filter Assembly (P/N 800-900)

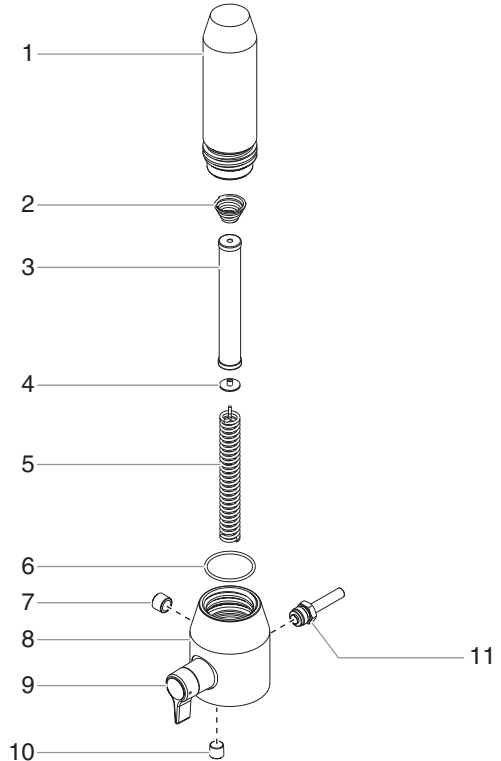

Item	Part #	Description	Quantity
1	800-905	Filter body	1
2	800-252	Filter spring	1
3	730-067	Filter, 60 mesh	1
4	702-251	Filter spring adapter.....	1
5	757-105	Core spring	1
6	800-906	O-ring, Teflon	1
7	800-908	Plug, 3/8"	1
8	800-901	Filter housing	1
9	800-915	PRIME/SPRAY valve assembly.....	1
10	800-907	Plug, 1/4"	1
11	800-437	Transducer.....	1

PRIME/SPRAY Valve Assembly (P/N 800-915)

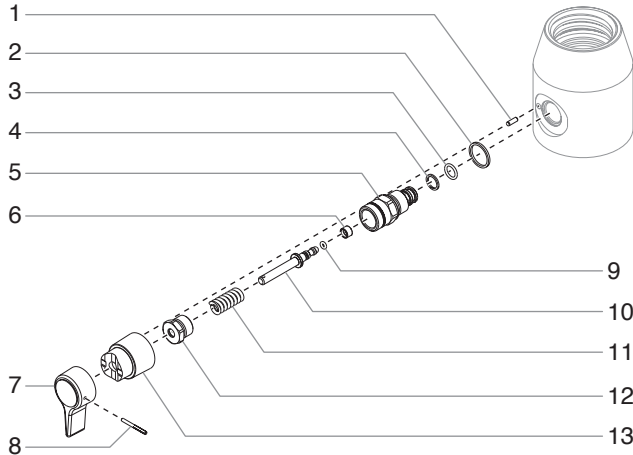

Item	Part #	Description	Quantity
1	700-823	Dowel pin	1
2	700-537	Gasket	1
3	222-012	O-ring, Teflon	1
4	221-012	O-ring, Viton.....	1
5	700-253	Valve housing	1
6	800-910	Valve seat	1
7	700-697	Valve handle	1
8	700-759	Groove pin	1
9	700-721	O-ring, Viton.....	1
10	700-250	Valve stem	1
11	800-926	Spring	1
12	700-248	Valve retainer.....	1
13	700-251	Cam base	1

Labels

Part #	Description
313-1781	3411 logo label
313-1673	Warning label (injection/explosion)
313-1847	Shock hazard label
313-1658	"Press to Reset" label
313-1848	Pressure control knob label
313-1867	Indicator lights label
313-1906	Infinity logo label

Accessories

Airless Tip Selection

Tips are selected by the orifice size and fan width. The proper selection is determined by the fan width required for a specific job and by the orifice size that will supply the desired amount of fluid and accomplish proper atomization.

For light viscosity fluids, smaller orifice tips generally are desired. For heavier viscosity materials, larger orifice tips are preferred. Please refer to the chart below.

NOTE: Do not exceed the sprayer's recommended maximum tip size.

The following chart indicates the most common sizes and the appropriate materials to be sprayed.

Tip Size	Spray Material	Filter Type
.011 — .013	Lacquers and stains	100 mesh filter
.015 — .019	Oil and latex	60 mesh filter
.021 — .026	Heavy bodied latex and blockfillers	30 mesh filter

Fan widths measuring 8" to 12" (20 to 30 cm) are preferred because they offer more control while spraying and are less likely to plug.

Liquid Shield Plus

Cleans and protects spray systems against rust, corrosion and premature wear.

Part No.	Description
314-483	4 ounce bottle
314-482	1 quart bottle

Piston Lube

Specially formulated to prevent materials from adhering to the piston rod, which becomes abrasive to the upper seals. Piston Lube will break down any material that may accumulate in the wet cup and keep it from drying.

Part No.	Description
314-481	4 ounce bottle
314-480	8 ounce bottle

Miscellaneous

Part No.	Description
490-012	Hose coupling, 1/4" x 1/4"
730-397	High-pressure fluid gauge
314-171	Lubriplate, 14 ounce individual
314-172	Lubriplate, 6 lb. can

Electrical Schematic

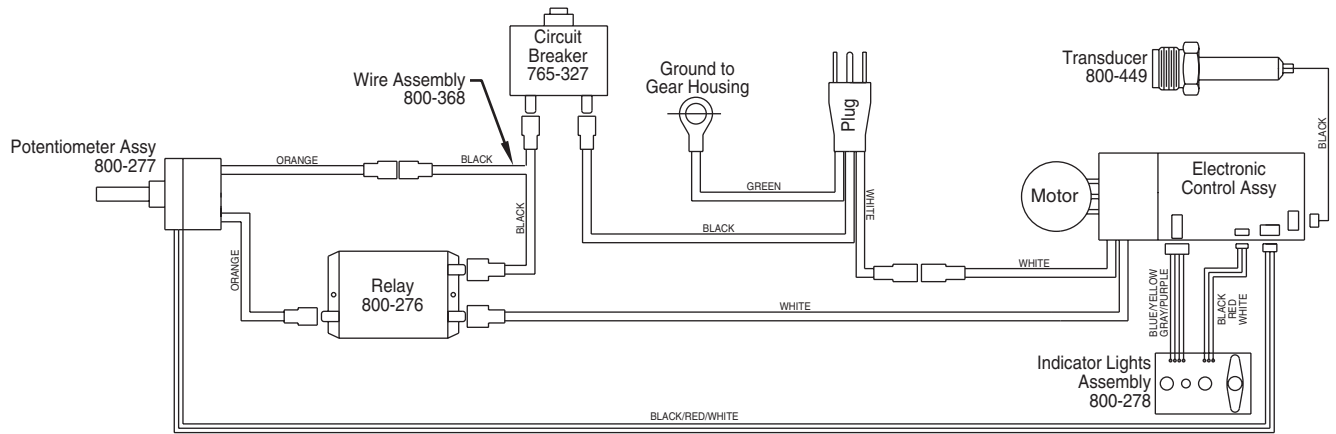

NOTE: All electrical work should be performed by a Titan authorized service center.

Warranty

Titan Tool, Inc., ("Titan") warrants that at the time of delivery to the original purchaser for use ("End User"), the equipment covered by this warranty is free from defects in material and workmanship. With the exception of any special, limited, or extended warranty published by Titan, Titan's obligation under this warranty is limited to replacing or repairing without charge those parts which, to Titan's reasonable satisfaction, are shown to be defective within twelve (12) months after sale to the End User. This warranty applies only when the unit is installed and operated in accordance with the recommendations and instructions of Titan.

This warranty does not apply in the case of damage or wear caused by abrasion, corrosion or misuse, negligence, accident, faulty installation, substitution of non-Titan component parts, or tampering with the unit in a manner to impair normal operation.

Defective parts are to be returned to an authorized Titan sales/service outlet. All transportation charges, including return to the factory, if necessary, are to be borne and prepaid by the End User. Repaired or replaced equipment will be returned to the End User transportation prepaid.

THERE IS NO OTHER EXPRESS WARRANTY. TITAN HEREBY DISCLAIMS ANY AND ALL IMPLIED WARRANTIES INCLUDING, BUT NOT LIMITED TO, THOSE OF MERCHANTABILITY AND FITNESS FOR A PARTICULAR PURPOSE, TO THE EXTENT PERMITTED BY LAW. THE DURATION OF ANY IMPLIED WARRANTIES WHICH CANNOT BE DISCLAIMED IS LIMITED TO THE TIME PERIOD SPECIFIED IN THE EXPRESS WARRANTY. IN NO CASE SHALL TITAN LIABILITY EXCEED THE AMOUNT OF THE PURCHASE PRICE. LIABILITY FOR CONSEQUENTIAL, INCIDENTAL OR SPECIAL DAMAGES UNDER ANY AND ALL WARRANTIES IS EXCLUDED TO THE EXTENT PERMITTED BY LAW.

TITAN MAKES NO WARRANTY AND DISCLAIMS ALL IMPLIED WARRANTIES OF MERCHANTABILITY AND FITNESS FOR A PARTICULAR PURPOSE WITH RESPECT TO ACCESSORIES, EQUIPMENT, MATERIALS OR COMPONENTS SOLD BUT NOT MANUFACTURED BY TITAN. THOSE ITEMS SOLD, BUT NOT MANUFACTURED BY TITAN (SUCH AS GAS ENGINES, SWITCHES, HOSES, ETC.) ARE SUBJECT TO THE WARRANTY, IF ANY, OF THEIR MANUFACTURER. TITAN WILL PROVIDE THE PURCHASER WITH REASONABLE ASSISTANCE IN MAKING ANY CLAIM FOR BREACH OF THESE WARRANTIES.

Material Safety Data Sheets (MSDS) are available on Titan's website or by calling Customer Service.



United States Sales & Service

1-800-526-5362

Fax 1-800-528-4826

107 Bauer Drive
Oakland, NJ 07436

www.titantool.com

Canadian Branch

1-800-565-8665

Fax 1-905-856-8496

200 Trowers Road, Unit 7B
Woodbridge, Ontario L4L 5Z8

International

1-201-337-1240

Fax 1-201-405-7449

107 Bauer Drive
Oakland, NJ 07436 USA