



Advanced Performance. Total Reliability.

Instruction Sheet

G-10 XL

High Capacity Spray Gun

| | |
|------------------|---------|
| 2-Finger w/tip | 0296236 |
| 4-Finger w/tip | 0296235 |
| 2-Finger w/tip | 0296306 |
| 2-Finger no tip | 0296307 |
| 4-Finger w/tip | 0296321 |
| 4-Finger, no tip | 0296322 |

Safety Precautions

IMPORTANT SAFETY INSTRUCTIONS



A. SAVE THESE INSTRUCTIONS – To reduce the risks of fire or explosion, electrical shock, and the injury to persons, read and understand all instructions included in this manual. Be familiar with the controls and the proper usage of the equipment.



B. WARNING – To reduce the risk of fire or explosion:

- Do not spray flammable or combustible materials near an open flame, pilot lights or sources of ignition such as hot objects, cigarettes, motors, electrical equipment and electrical appliances. Avoid creating sparks from connecting and disconnecting power cords.
- Use extreme caution when using materials with a flashpoint below 70°F (21°C). Flashpoint is the temperature that a fluid can produce enough vapors to ignite.
- Paint or solvent flowing through the equipment is able to result in static electricity. Static electricity creates a risk of fire or explosion in the presence of paint or solvent fumes. All parts of the spray system, including the pump, hose assembly, spray gun and objects in and around the spray area shall be properly grounded to protect against static discharge and sparks. Use only conductive or grounded high-pressure airless paint sprayer hoses specified by the manufacturer.
- Verify that all containers and collection systems are grounded to prevent static discharge.
- Connect to a grounded outlet and use grounded extension cords (electric models only). Do not use a 3 to 2 adapter.
- Do not use a paint or solvent containing halogenated hydrocarbons. Such as chlorine, bleach mildewcide, methylene chloride and trichloroethane. They are not compatible with aluminum. Contact the coating supplier about compatibility of material with aluminum.
- Keep spray area well ventilated. Keep a good supply of fresh air moving through the area to keep the air within the spray area free from accumulation of flammable vapors. Keep pump assembly in well ventilated area. Do not spray pump assembly.
- Do not smoke in the spray area.
- Do not operate light switches, engines, or similar spark producing products in the spray area.
- Keep area clean and free of paint or solvent containers, rags, and other flammable materials.
- Know the contents of the paint and solvents being sprayed. Read all Material Safety Data Sheets (MSDS) and container labels provided with the paints and solvents. Follow the paint and solvent manufacture's safety instructions.
- Place pump at least 25 feet (7.62 meters) from the spray object in a well ventilated area (add more hose if necessary). Flammable vapors are often heavier than air. Floor area must be extremely well ventilated. The pump contains arcing parts that emit sparks and can ignite vapors.
- Plastic can cause static sparks. Never hang plastic to enclose spray area. Do not use plastic drop cloths when spraying flammable material.
- Fire extinguisher equipment shall be present and working.



C. WARNING – To reduce the risk of skin injection:

HAZARD:

Injection Injury - A high pressure fluid stream produced by this equipment can pierce the skin and underlying tissues, leading to a serious injury and possible amputation. See a physician immediately. DO NOT TREAT AN INJECTION INJURY AS A SIMPLE CUT.

- Do not aim the gun at, or spray any person or animal.
- Keep hands and other body parts away from the discharge. For example, do not try to stop leaks with any part of the body.

- Always use the nozzle tip guard. Do not spray without the nozzle tip guard in place.
- Only use a nozzle tip specified by the manufacturer.
- Use caution when cleaning and changing nozzle tips. In the case where the nozzle tip clogs while spraying, ALWAYS lock gun trigger, shut pump off, and release all pressure before servicing, cleaning tip or guard, or changing tip. Pressure will not be released by turning off the motor. The PRIME/SPRAY valve handle must be turned to PRIME to relieve the pressure. Refer to PRESSURE RELIEF PROCEDURE described in the pump manual.
- Do not leave the unit energized or under pressure while unattended. When the unit is not in use, turn off the unit and relieve the pressure in accordance with the manufacturer's instructions.
- High-pressure spray is able to inject toxins into the body and cause serious bodily injury. In the event that injection occurs, seek medical attention immediately.
- Check hoses and parts for signs of damage, a leak can inject material into the skin. Inspect hose before each use. Replace any damaged hoses or parts.
- This system is capable of producing 3600 PSI / 25 MPa. Only use replacement parts or accessories that are specified by the manufacturer and that are rated a minimum of 3600 PSI. This includes spray tips, nozzle guards, guns, extensions, fittings, and hose.
- Always engage the trigger lock when not spraying. Verify the trigger lock is functioning properly.
- Verify that all connections are secure before operating the unit.
- Know how to stop the unit and bleed pressure quickly. Be thoroughly familiar with the controls. Pressure will not be released by turning off the motor. The PRIME/SPRAY valve handle must be turned to PRIME to relieve the pressure. Refer to PRESSURE RELIEF PROCEDURE described in the pump manual.
- Always remove the spray tip before flushing or cleaning the system.



D. WARNING – To reduce the risk of injury:

- Always wear appropriate gloves, eye protection, clothing and a respirator or mask when painting. Hazardous vapors – Paints, solvents, insecticides, and other materials can be harmful if inhaled or come in contact with body. Vapors can cause severe nausea, fainting or poisoning.
- Do not operate or spray near children. Keep children away from equipment at all times.
- Do not overreach or stand on an unstable support. Keep effective footing and balance at all times.
- Stay alert and watch what you are doing.
- Do not operate the unit when fatigued or under the influence of drugs or alcohol.
- Do not kink or over-bend the hose. Airless hose can develop leaks from wear, kinking and abuse. A leak can inject material into the skin.
- Do not expose the hose to temperatures or pressures in excess of those specified by manufacturer.
- Do not use the hose as a strength member to pull or lift the equipment.
- Use lowest possible pressure to flush equipment.
- Follow all appropriate local, state and national codes governing ventilation, fire prevention and operation.
- The United States Government Safety Standards have been adopted under the Occupational Safety and Health Act (OSHA). These standards, particularly part 1910 of the General Standards and part 1926 of the Construction Standards should be consulted.
- Before each use, check all hoses for cuts, leaks, abrasion or bulging of cover. Check for damage or movement of couplings. Immediately replace hose if any of those conditions exist. Never repair a paint hose. Replace with a conductive high-pressure hose.
- Do not spray outdoors on windy days.
- Always unplug cord from outlet before working on equipment.

Using the Gun Trigger Lock

Always engage the gun's trigger lock when the gun is not in use.

1. To lock the trigger, rotate the trigger lock forward until it stops.
2. To unlock the trigger, rotate the trigger lock backward until it is vertical.

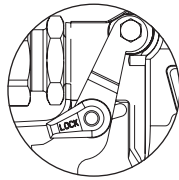

Trigger locked
(gun will not spray)

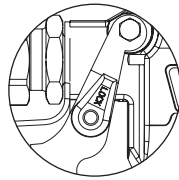

Trigger unlocked
(gun will spray)

Setup



Never attempt to assemble, change, or clean the gun, tip, or tip guard without first relieving pressure from the spray system. Follow the "Pressure Relief Procedure" in the sprayer's Owner's Manual.



Always use a tip safety guard for added protection against injection. Beware that the guard alone will not prevent injection. Never cut off tip guard! Always engage gun trigger lock when the gun is not in use. Before servicing equipment, consult Owner's Manuals and follow all warnings.

1. Set up the sprayer. Refer to the instructions in the sprayer's Owner's Manual.
2. Attach a grounded, airless spray hose to the material inlet on the gun. Using two wrenches (one on the gun and one on the hose), tighten securely.
3. With the tip and tip guard off the gun, start the sprayer. Flush and prepare the spray system according to the sprayer's Owner's Manual. Inspect the spray system to make sure that all fittings are secure and that there are no leaks.
4. Perform the "Pressure Relief Procedure" described in the sprayer's Owner's Manual.
5. Using a pen or similar object, insert the tip seal and seal into the back of the tip guard. Press in for final adjustment.
6. Insert the tip into the slot on the tip guard.
7. Thread the tip guard onto the gun. Position the tip guard in the desired spraying position, then tighten securely by hand.

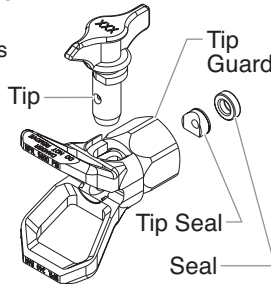

NOTE: The arrow on the tip handle should be pointing in the forward direction for spraying.

Operation

1. Make sure the arrow on the tip handle is pointing in the forward direction for spraying.
2. Start the sprayer. Refer to the instructions in the sprayer's Owner's Manual.
3. Adjust the fluid pressure on the sprayer until the spray is completely atomized. Always spray at the lowest pressure necessary to get the desired results.

NOTE: The spray tip determines the size of spray pattern and coverage. When more coverage is needed, use a larger tip instead of increasing fluid pressure.

4. To clear a clogged tip:
 - a. Rotate the tip 180° so that the arrow on the tip handle is pointing opposite the spray direction.
 - b. Trigger the gun once so that the pressure can blow the clog out.

IMPORTANT: Never pull the trigger more than once at time with the tip in the reverse position.

- c. Continue this procedure until the tip is clear of the clog.

Changing a Tip

Tips can be removed and replaced easily without disassembling the gun.



Never attempt to change or clean the tip or tip guard without first performing the "Pressure Relief Procedure."

1. Perform the "Pressure Relief Procedure" described in the sprayer's Owner's Manual.
2. Remove the tip from the slot on the tip guard.
3. Insert the new tip into the slot on the tip guard. The arrow on the tip handle should be pointing in the forward direction for spraying.

Removing the Seal and Tip seal

1. Remove the tip and tip guard from the spray gun.
2. Remove the seal and tip seal from the back of the tip guard.

Identifying Tip Sizes

To identify tip sizes, use the following formula. A "517" tip size will be used in this example.

The first digit multiplied by two represents the size of the spray pattern when spraying 12" away from the work surface:

$$5 \times 2 = 10" \text{ spray pattern}$$

The second two digits represent the diameter of the orifice on the tip:

$$17 = .017" \text{ orifice}$$

NOTE: Worn spray tips will adversely affect the spray pattern and result in reduced production, poor finish, and wasted material. Replace worn tips immediately.

Cleanup

Maintaining a clean gun is important to ensure trouble-free operation. Flush the gun after each use and store in a dry location. Do not leave the gun or any of its parts in water or solvents.



Special cleanup instructions for use with flammable solvents:

- Always flush spray gun preferably outside and at least one hose length from spray pump.
- If collecting flushed solvents in a one gallon metal container, place it into an empty five gallon container, then flush solvents.
- Area must be free of flammable vapors.
- Follow all cleanup instructions.

IMPORTANT: The sprayer, hose, and gun should be cleaned thoroughly after daily use. Failure to do so permits material to cake, seriously affecting the performance of the unit.



Always spray at minimum pressure with the tip and tip guard removed when using mineral spirits or any other solvent to clean the sprayer, hose, or gun. Static electricity buildup may result in a fire or explosion in the presence of flammable vapors. Hold the gun firmly against a metal container while flushing.

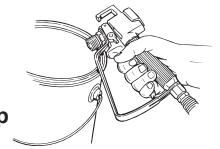

Maintenance



Follow all safety precautions as described in the Safety Precautions section of this manual before proceeding.

NOTE: Refer to the Parts List section in this manual for part identification.

Replacing/Serviceing the Seal Assembly

If your spray gun leaks or spits at the tip when you release the trigger, the needle or seat is worn, damaged, or dirty and must be replaced or cleaned.



Never attempt to perform maintenance on the spray gun without first performing the "Pressure Relief Procedure."

1. Disconnect the fluid hose from the gun.
2. Remove the tip and tip guard.
3. With the trigger depressed, remove the diffuser from the front of the gun.
4. Remove the lock nut, rear housing, and retractor pins from the rear of the gun head.
5. Remove the seal assembly from the front of the gun head by pushing or gently tapping at the back of the seal assembly.
6. Soak the removed parts in the appropriate solvent and wipe clean.
7. Inspect the parts for wear or damage and use new parts during reassembly of the gun, when necessary.

NOTE: Lubricate all packings and moving parts before reassembly with a lithium-based grease.

8. Install the seal assembly into the front of the gun head.
9. Install the retractor pins into the rear of the gun head. Slide the rear housing onto the retractor pins and secure in position with the lock nut.
10. With the trigger depressed, install the diffuser into the front of the gun head and tighten securely with a wrench.
11. Perform the "Adjusting the Seal Assembly" procedure described below.

Adjusting the Seal Assembly



Proper adjustment of the seal assembly is essential to ensure positive shut-off when the trigger is released.

1. Tighten the lock nut until the rear housing is flush against the gun head.
2. Unscrew the lock nut 3/4 of a turn.

NOTE: To check the adjustment of the seal assembly:

1. Move the gun trigger lock to the locked position.
2. Pull the trigger.

With the trigger lock engaged, there should be 1/32" of movement between the lock nut and the rear housing while pulling the trigger.

Replacing/Removing the Filter

1. Pull the bottom of the trigger guard forward so that it comes loose from the handle assembly.
2. Loosen and remove the handle assembly from the gun head.
3. Pull the old filter out of the gun head.
4. Slide the new filter, tapered end first, into the gun head.
5. Make sure the handle seal is in position and thread the handle assembly into the gun head until secure.
6. Snap the trigger guard back onto the handle assembly.

Gun Filter Chart

| Part Number | Application | Filter Type | Color of Filter Body |
|-------------|--|-------------|----------------------|
| 0089960 | Synthetic resin, enamels, clean varnishes, stains azures | Extrafine | red |
| 0089959 | Base coat enamels, primer enamels, fillers, marking paints, textured enamels | Fine | yellow |
| 0089958 | Emulsions, latex paints, acrylic paints | Medium | white |
| 0089957 | Filler paints, large area surfaces | Coarse | green |

Parts List

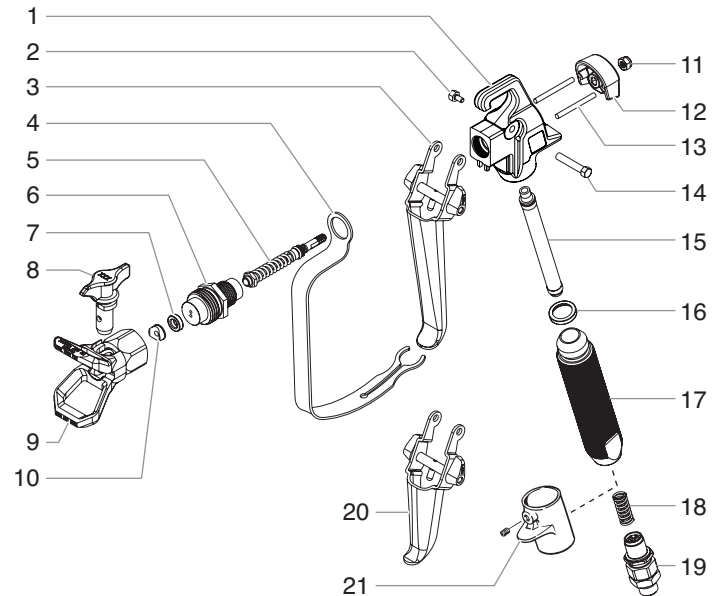

| Item | Part # | Description | Quantity |
|------|---------|--|----------|
| 1 | 0296228 | Gun head..... | 1 |
| 2 | 0296284 | Trigger screw, short..... | 1 |
| 3 | 0296285 | Trigger assembly, 4-finger gun..... | 1 |
| 4 | 0296230 | Trigger guard..... | 1 |
| 5 | 0296270 | Seal assembly..... | 1 |
| 6 | 0296404 | Diffuser..... | 1 |
| 7 | 0297045 | Seal..... | 1 |
| 8 | 661-517 | Tip assembly, (includes items 7 and 10)..... | 1 |
| 9 | 661-012 | Tip guard..... | 1 |
| 10 | 0297007 | Tip seal..... | 1 |
| 11 | 9910201 | Lock nut..... | 1 |
| 12 | 0296222 | Rear housing..... | 1 |
| 13 | 0296286 | Retractor pin..... | 2 |
| 14 | 0296287 | Trigger screw, long..... | 1 |
| 15 | 0089958 | Filter, medium..... | 1 |
| 16 | 0296289 | Handle seal..... | 1 |
| 17 | 0296342 | Handle..... | 1 |
| 18 | 0296343 | Spring..... | 1 |
| 19 | 0347706 | Swivel..... | 1 |
| 20 | 0296291 | Trigger assembly, 2-finger gun..... | 1 |
| 21 | 0279185 | Collar assembly, 2-finger gun..... | 1 |
| | 0296345 | Handle assembly (includes items 17-19) | |
| | 0296294 | Gun repair kit (includes items 5, 6, and 11) | |

Warranty

Titan Tool, Inc., ("Titan") warrants that at the time of delivery to the original purchaser for use ("End User"), the equipment covered by this warranty is free from defects in material and workmanship. With the exception of any special, limited, or extended warranty published by Titan, Titan's obligation under this warranty is limited to replacing or repairing without charge those parts which, to Titan's reasonable satisfaction, are shown to be defective within twelve (12) months after sale to the End User. This warranty applies only when the unit is installed and operated in accordance with the recommendations and instructions of Titan.

This warranty does not apply in the case of damage or wear caused by abrasion, corrosion or misuse, negligence, accident, faulty installation, substitution of non-Titan component parts, or tampering with the unit in a manner to impair normal operation.

Defective parts are to be returned to an authorized Titan sales/service outlet. All transportation charges, including return to the factory, if necessary, are to be borne and prepaid by the End User. Repaired or replaced equipment will be returned to the End User transportation prepaid.

THERE IS NO OTHER EXPRESS WARRANTY. TITAN HEREBY DISCLAIMS ANY AND ALL IMPLIED WARRANTIES INCLUDING, BUT NOT LIMITED TO, THOSE OF MERCHANTABILITY AND FITNESS FOR A PARTICULAR PURPOSE, TO THE EXTENT PERMITTED BY LAW. THE DURATION OF ANY IMPLIED WARRANTIES WHICH CANNOT BE DISCLAIMED IS LIMITED TO THE TIME PERIOD SPECIFIED IN THE EXPRESS WARRANTY. IN NO CASE SHALL TITAN LIABILITY EXCEED THE AMOUNT OF THE PURCHASE PRICE. LIABILITY FOR CONSEQUENTIAL, INCIDENTAL OR SPECIAL DAMAGES UNDER ANY AND ALL WARRANTIES IS EXCLUDED TO THE EXTENT PERMITTED BY LAW.

TITAN MAKES NO WARRANTY AND DISCLAIMS ALL IMPLIED WARRANTIES OF MERCHANTABILITY AND FITNESS FOR A PARTICULAR PURPOSE WITH RESPECT TO ACCESSORIES, EQUIPMENT, MATERIALS OR COMPONENTS SOLD BUT NOT MANUFACTURED BY TITAN. THOSE ITEMS SOLD, BUT NOT MANUFACTURED BY TITAN (SUCH AS GAS ENGINES, SWITCHES, HOSES, ETC.) ARE SUBJECT TO THE WARRANTY, IF ANY, OF THEIR MANUFACTURER. TITAN WILL PROVIDE THE PURCHASER WITH REASONABLE ASSISTANCE IN MAKING ANY CLAIM FOR BREACH OF THESE WARRANTIES.

The logo for Titan Tool, Inc. features the word "TITAN" in a bold, italicized, sans-serif font. The letters are black with a white outline, and a small "TM" trademark symbol is positioned to the upper right of the final letter.

United States Sales & Service

Phone: 1-800-526-5362
Fax: 1-800-528-4826

1770 Fernbrook Lane
Minneapolis, MN 55447
www.titantool.com

Canadian Branch

Phone: 1-800-565-8665
Fax: 1-800-856-8496

200 Trowers Road, Unit 7B
Woodbridge, Ontario L4L 5Z8

International

Phone: 1-201-337-1240
Fax: 1-201-405-7449

1770 Fernbrook Lane
Minneapolis, MN 55447